



CITY OF MATTAWA
COUNCIL MEETING AGENDA
February 01, 2024
5:30 P.M.

Call to Order:

Roll Call: Mayor Maria Celaya, Sun Hwang, Brian Berghout, Silvia Barajas, Tony Acosta,
Alex Heredia, Fabiola Hernandez, Wendy Lopez

I. Additions/Approval of Agenda:

II. Public Comments

III. Consent Agenda/Informational:

- Minutes- Council Meeting 01.18.24
- Gray & Osborne Project Summary 01.24.24
- 2024 Claims EFT & Checks Approval #20262-20280 - \$40,740.14
- 2024 Payroll EFT & Checks Approval #31918-31923 - \$130,429.85

IV. Reports:

Mayor Report

Council Report

Police Department Report

Public Works Department Report

V. Council, Items for Motion (Old Business):

1. Budget Subcommittee - Selection of Chair Member

VI. Council, Items for Motion (New Business):

1. Event Permits - Our Lady of the Desert Parish - Corrections
2. Ordinance 24-691 Amending Chapter 10.20 Truck Regulations
3. Updating 2018 Construction Standards

VII. Executive Session: RCW 42.30.110 (1g) To evaluate the qualifications of an applicant for public employment.

VIII. Adjournment:

- Gray & Osborne Project Summary 01.10.24
- 2023 Claims EFT & Checks Approval #20231-20255 - \$123,520.84
- 2024 Claims EFT & Checks Approval #20230, 20256-20261 - \$267,669.93
- 2024 Payroll EFT Approval - \$12,300.00

** Approval of Claims, Prepaid Claims and Payroll Vouchers audited and certified by the City Clerk as required by RCW 42.24.080, and those expense reimbursement claims, certified as required by RCW 42.24.090, have been recorded on a listing which has been made available to the Council for approval and is retained for public inspection at city hall.

** As of January 18th, 2024, the Council approved payment of 2023 Claims EFT & checks approval #20231-20255 in the amount of \$123,520.84, 2024 Claims EFT & Checks approval #20230, 20256-20261 in the amount of \$267,669.93, 2024 Payroll EFT approval in the amount of \$12,300.00.

**** M/s; Berghout / Acosta motion that bill, checks, payroll, 01.04.24 meeting minutes be approved. Motion carried.**

V. Reports:

Mayor's Report

- ** There was a food distribution last Thursday on Manson Lane.
- ** Apollo's Food distribution will be on Fridays.

Council Report

- ** Councilman Berghout mentioned the DSHS office will now be open at the WIC office location.
- ** Councilwoman Hernandez & Councilman Hwang attended the Law enforcement appreciation luncheon.
- ** Councilman Heredia said CAD Homes is having a 1st time buyer meeting at the school on Saturday.

Police Department Report

- ** No Report

Public Works Department Report

- ** WWTF: The fine screen & chloride injector froze at the treatment plant, currently working on thawing.
- ** WWTF improvements: Project is ongoing. There is little advancement due to the weather.
- ** Councilman Berghout thanked the department for clearing sidewalks with tractor.

** Councilwoman Lopez asked what the timeframe for residents is to remove snow on sidewalks. Juan responded that typically after the storm.

** Councilwoman Lopez also asked about sending out information to residents on the dangers of carbon monoxide due to heaters. Ms. Lopez also asked about the few homeless individuals, Mayor Celaya said that a certain individual already has a place to stay and is in communication is law enforcement.

VI. Council, Items for Motion (Old Business):

1. None.

VII. Council, Items for Motion (New Business):

1. **Ord. 24-690 2023 Periodic Update & Comp. Plan Adoption**
Councilwoman Hernandez has a few comments and clarifications of the comp. plan.
M/s; Acosta / Heredia approve plan with corrections. Motion carried.
2. **Council Committee – AWC Center for Quality Communities Scholarship**
Students can submit their applications to the council for review and selection for the AWC Scholarship.
- No action needed.
3. **Resolution 24.01.02 Community Events 2024**
Councilman Acosta would like to reduce the city staff overtime and shift the work to city volunteers to assist with events.
M/s; Acosta / Lopez motion to approve with clause to reduce city staff overtime.
Motion carried.
4. **Event Permit – Palm Sunday Walking Procession**
M/s; Berghout / Lopez motion to seek clarification if public services are needed and notify of additional cost. Motion carried.
5. **Event permit – Silence Procession**
M/s; Acosta / Hernandez motion to approve this event as presented. Opposed, Heredia & Lopez. Motion carried.
6. **Legislative Appropriations Application**
Last year the city submitted for well funds and that was not successful. The city would like to submit again for city hall improvements. Juan said there are some funds in the capital improvement fund approx. 161k to match funds.
M/s; Heredia / Acosta motion to approve seeking with 50k matching funds. Motion carried.
7. **Letter of Support – WSD SPF-PFS Project**
M/s; Berghout / Acosta motion to add this letter to agenda. Motion carried.

M/s Berghout / Acosta motion to approve mayor to sign letter.

IX. Adjournment:

The council meeting was adjourned at 7:09 P.M. M/s; Berghout/ Heredia. Motion carried.

Respectfully submitted,

Anabel Martinez, City Clerk

Maria Celaya, Mayor

Gray & Osborne/City of Mattawa Project Summary (1/24/24)

Development Projects

Hwang Subdivision – Mike Meskimen, Julio Renteria

Project Number: 21845.05

Funded: Developer Contributions

- Preliminary subdivision approval granted
- Future development agreement required
- No active review requirements
- **Currently undergoing preliminary plat review process**

Bodrero Development – Mike Meskimen, Nancy Wetch

Project Number: 21845.07

Funded: Developer Contributions

- Preliminary subdivision review period complete
- **Currently undergoing the construction drawing review process**

WGL Mattawa Slope Phase III – Mike Meskimen, Jamin Ankney

Project Number: 21845.12

Funded: Developer Contributions

- **Progress has started on the Phase III of this project**
- **G&O reviewed building permit documents and provided comments**

Lopez Subdivision – Jamin Ankney, Mike Meskimen

Project Number: 21845.15

Funded: Developer Contributions

- **G&O reviewed subdivision and provided comments.**

Transportation Projects

Government Road Multi-Use Pathway – Julio Renteria, Mike Meskimen, Russ Powers (funding)

Project Number: 20854

Funded: CDBG/City Funds (Developer Contributions)

- 10-foot-wide path from Steven Street to Mansion.
- **Construction closeout ongoing**
- **Total Budget: \$715,000**

Riverview Avenue Improvements

Project Number: 23844

Project Completion: TBD

Funded: TIB

- Design completed

- Bid received was significantly over the City's budget
- Considering options for the project
- **Total Budget: \$100,000**

TIB Applications – Mike Meskimen, Julio Renteria, Michael Woodkey

Project Number: OH230.42

- Applications were due August 11, 2023
- Funding was not awarded.
- City will likely receive a different TIB funding offer in the next year.

Government Road Feasibility Study Update – Mike Meskimen, Julio Renteria, Michael Woodkey

- Cost ranges for update provided by G&O
- City to determine next steps desired
- City may budget this effort for next year

Water System Projects

Water System Plan – Jamin Ankney, Jared McMeen

Project Number: 20854

Project Completion: November 2023

Funded: City Water Fund

- Completed response to all DOH comments
- DOH has approved, but discussion of approval conditions is pending.
- DOH is requiring an additional capacity analysis.
- **Total Budget \$62,700**

Well 2 Rehabilitation – Jared McMeen, Steve Wagner, Jamin Ankney, Aspect Consulting

Project Number 22867

Project Completion: September 2023

Funded: City Water Fund

- Rehabilitation efforts are ongoing
- Work is substantially complete
- Initial pump test results were positive
- Aspect Consulting has prepared a summary report and recommendations based on rehabilitation results
- **Engineering Budget: \$266,237 (combined between rehabilitation and design)**
- **Construction Budget: \$157,000**

Well 2 – Re-equipping Design – Jamin Ankney, Jared McMeen, Justin Wies

Project Number 22867

Project Completion: June 2024

Funded: City Water Fund

- Design will be ongoing throughout the winter and spring
- Additional design questions for discussion with City staff
- **Total Budget: \$266,237**

Re-equipping Well 2 Construction/Well 5/Pressure Zone Improvements – Jamin Ankney, Jared McMeen, Russ Powers (funding)

- Applied for Congressional Funding Application – May receive funding
- Applied for Legislative Appropriation – Did not receive funding
- Applied to CDBG – Did not receive funding
- Applied to PWB – Received funding
- Applied to DWSRF – Funding application is under DOH review.
- Added SCADA upgrades to funding application to DWSRF
- **Total Budget: \$7,000,000**

Future/Pending Water System Projects

Water Rights – Aspect Consulting, Jamin Ankney

- **Total Budget: Not an active project**

Reservoir Project – Jamin Ankney, Myron Basden

- Coating Project
- Reservoir No. 1 – No need to evaluate until 2029.
- Reservoir No. 2 – Need to evaluate in 2025 for potential coating project.
- **Total Budget: Not an active project**

SCADA – Jamin Ankney, Brad Bailey (Conley Engineering)

- **Total Budget: Not an active project**
- City has had recent issues with the SCADA system and is working with Connetix to address the issues.
- Based on results of troubleshooting, a SCADA upgrade may be required in the future.
- Connetix provided a cost estimate for improvements for use in procuring future funding
- Upgrades are estimated to cost around \$220,000.

Wastewater System Projects

WWTF Fire Assistance – Nancy Wetch, Russ Powers

Project Number: 20827

Project Completion: November 2023

Funded: Insurance Reimbursement/City Funds (Ecology Emergency Funding)

- Phase 1 – Blower Procurement
- Phase 2 – Building Restoration
- Phase 3 – Equipment Installation

- **Total Budget:** *The total cost of the fire response, cleanup, design, construction, etc., is not completely known at this time as costs are still being assembled and approved by the insurance company.*

Initial Emergency Response (G&O does not have total cost)

Engineering: \$414,840 *(insurance will reimburse)*

Phase I: \$93,505.84 *(insurance will reimburse)*

Phase II: \$320,864 *(insurance will reimburse)*

Phase III: \$1,189,148 *(working on insurance reimbursement, City will be responsible for some costs – TBD)*

- City has all costs in hand and can proceed with closeout
- The City will still need to pay the retainage to Apollo, but can request this from the insurance now
- A few warranty items remain for Apollo to complete
- Apollo produced invoices for use by the City with the insurance company

WWTF Improvements Construction – Tim DeVries, Nancy Wetch, Jamin Ankney

Project Number: 19044.01

Project Completion: 2024 (for construction completion)

Funded: Ecology Water Quality Funding

- Construction is ongoing – project is going well
- Current schedule appear to extend beyond the allowed construction days – working to obtain updated schedule
- Facility plan amendment required for Ecology approval of funding for control panel replacement
- **Total Budget \$5,883,000 (includes design, construction, construction administration)**

WWTF Solids Handling Analysis – Nancy Wetch, Arn Coombs

Project Number: 23813

Project Completion: January 2024

- This work is currently ongoing
- Will have draft for City review in the next few months
- **Total Budget \$24,200**

Portage Avenue Lift Station Elimination – Nancy Wetch, Jamin Ankney

Project Number: OH220.72

Project Completion: 2025

- Ecology funding approved
- Waiting for funding agreement, likely winter 2024
- **GMA compliance will be require for this funding to be received.**
- **Total Budget \$2,417,000**

Other Projects

Construction Standards Update – Jamin Ankney, Jared McMeen

Project Number: 23826

Project Completion: December 2023

Funded: City Funds

- A draft of the updated construction standards are currently under City review.
- The draft was updated to include stricter stormwater requirements.
- **Total Budget \$3,000**

Park Planning – SCJ, Russ Powers, Jamin Ankney

- City has received funding from RCO.
- Needs to be in City's Comprehensive Plan (SCJ Discussions)
- Currently completing contracting with RCO
- Combined project for SCJ + G&O
- **SCJ has started work on this project.**
- **Community workshop completed on Friday, December 15.**
- **COAF funding discussion**
- **Total Budget \$60,000**

Basketball Courts – Julio Renteria

Project Number 22861

Project Completion: TBD

Funded: Foundation Grant

- Bids received exceed funding
- **City reduced the scope and obtained additional quotes**
- **Work on this project is ongoing.**
- **Total Budget \$125,000**

City Hall Feasibility Analysis – Jamin Ankney, Myron Basden

Project Number 23856

Project Completion: November 2023

Funded: City

- Electrical review was completed Monday, September 18
- Structural/HVAC review was completed Monday, October 2
- Memo report was submitted today for staff and council review prior to the November 2 council meeting.
- The 60-day due diligence period ended on November 14
- **City could consider funding options for the selected alternative.**
- **City may consider proceeding with conceptual design to aid in future funding efforts.**
- **G&O has prepared a draft legislative appropriation application**
- **Total Budget \$27,700**

Next Meeting – February 7, 2024, 3:30 p.m.

ACCOUNTS PAYABLE

City Of Mattawa

As Of: 02/01/2024

Time: 15:24:08 Date: 01/30/2024

Page: 1

Accts Pay #	Received	Date Due	Vendor	Amount	Memo		
16911	02/01/2024	02/01/2024	3627		ANATEX LABS INC-SPOKANE	300.00	RC Samples
	534 10 41 02	Chemical Samples	401 000 534	Water Operatin	240.00	RC DW Samples	
	535 10 41 02	Testing Samples	405 000 535	Sewer Operatin	60.00	WWTF RC Samples	
16897	02/01/2024	02/01/2024	2912		AXON ENTERPRISE, INC	7,171.32	MPD- Body Dock:Evidence Storage:Body Cameras
	591 21 70 01	Axon Body Cameras	001 000 591	Current Expens	7,171.32	MPD- Body Dock:Evidence Storage:Body Cameras	
16906	02/01/2024	02/01/2024	1886		CENTURY LINK	73.22	Lift Station
	535 10 42 00	Telephone	405 000 535	Sewer Operatin	73.22	Lift Station	
16907	02/01/2024	02/01/2024	1886		CENTURY LINK	133.24	WWTF SCADA
	535 10 42 00	Telephone	405 000 535	Sewer Operatin	133.24	WWTF SCADA	
16905	02/01/2024	02/01/2024	443		CITY OF MATTAWA-PETTY CASH	74.84	Petty Cash
	514 23 31 00	Postage	001 000 514	Current Expens	69.84	Letter Out In Regards Containers	
	518 30 47 14	City Hall Utilities	001 000 518	Current Expens	5.00	Drinking Water	
16889	02/01/2024	02/01/2024	99		COMMERCIAL TIRE CO	928.47	PW- Vehicle Maint.
	534 10 48 02	Vehicle Repair & Maintena	401 000 548	Water Operatin	928.47	PW- Vehicle Maint.- Alberto Truck	
16890	02/01/2024	02/01/2024	99		COMMERCIAL TIRE CO	943.62	PW- Vehicle Maint.
	535 10 48 03	Vehicle Repair / Maintenanc	405 000 535	Sewer Operatin	943.62	PW- Vehicle Maint.- Jose Truck	
16892	02/01/2024	02/01/2024	3679		CORRECT SERVING WATER & WASTEWATER U'	650.40	Chlorine RM
	534 10 48 03	System Repair & Maintena	401 000 534	Water Operatin	650.40	Chlorine RM	
16902	02/01/2024	02/01/2024	3183		GRANT COUNTY ELECTIONS	484.75	Election Costs
	514 40 50 00	Election Costs	001 000 514	Current Expens	484.75	Election Costs	
16899	02/01/2024	02/01/2024	1698		GRANT COUNTY PUD	2,404.63	Power Billing December 2023
	534 10 47 01	Utilities	401 000 534	Water Operatin	194.28	709 1st Street	
	535 10 47 00	Utilities	405 000 535	Sewer Operatin	1,781.03	U Rd	
	535 10 47 01	LID Sewer Assess Fees	405 000 535	Sewer Operatin	69.96	8th Street	
	576 80 47 00	Park Utilities	001 000 576	Current Expens	100.21	104 Portage Ave	
	576 80 47 00	Park Utilities	001 000 576	Current Expens	259.15	710 1st Street	
16900	02/01/2024	02/01/2024	1698		GRANT COUNTY PUD	1,555.70	Power Billing December 2023

ACCOUNTS PAYABLE

City Of Mattawa

As Of: 02/01/2024

Time: 15:24:08 Date: 01/30/2024

Page: 2

Accts Pay #	Received	Date Due	Vendor	Amount	Memo
518 30 47 14	City Hall Utilities		001 000 518 Current Expens	172.23	City Hall
534 10 47 01	Utilities		401 000 534 Water Operatin	1,123.55	707 2nd
534 10 47 01	Utilities		401 000 534 Water Operatin	45.40	Boundary Ave
572 20 47 00	Library - Utility Services		001 000 572 Current Expens	113.97	Library
576 80 47 00	Park Utilities		001 000 576 Current Expens	24.15	Park
576 80 47 00	Park Utilities		001 000 576 Current Expens	26.48	Manson Lane
576 80 47 00	Park Utilities		001 000 576 Current Expens	27.17	Contorl Circuit
576 80 47 00	Park Utilities		001 000 576 Current Expens	22.75	Outlets
16893	02/01/2024	02/01/2024	1900 MATTAWA TIRE SERVICES LLC	32.55	MPD- Vehicle Maint.
521 20 48 00	Vehicle Repair And Mainteri		001 000 521 Current Expens	32.55	MPD- Vehicle Maint.
16886	02/01/2024	02/01/2024	2885 MILBRANDT VINEYARDS, INC	100.00	Refund Utility Deposit
589 30 01 00	Deposit Refunds - Custome		403 000 580 Customer Depo	100.00	Refund Utility Deposit
16895	02/01/2024	02/01/2024	324 MULTI AGENCY COMMUNICATION CENTER	2,481.70	Dispatch Service Feb. 2024
522 20 42 02	MACC - Communications		107 000 522 Public Safety T:	2,481.70	Dispatch Service Feb. 2024
16908	02/01/2024	02/01/2024	2729 QUADIENT FINANCE USA INC.	250.00	Postage Machine
514 23 31 00	Postage		001 000 514 Current Expens	83.34	Postage Machine
534 10 30 02	Postage		401 000 534 Water Operatin	83.34	Postage Machine
535 10 31 01	Postage		405 000 535 Sewer Operatin	83.32	Postage Machine
16887	02/01/2024	02/01/2024	3299 SOILTEST FARM CONSULTANTS INC	336.00	RC Samples
535 10 41 02	Testing Samples		405 000 535 Sewer Operatin	336.00	RC Samples
16904	02/01/2024	02/01/2024	3297 SPRINGBROOK HOLDING COMPANY LLC	10,224.97	Annual Support Software Services 2024
518 80 41 01	Computer Support/Mainten		001 000 518 Current Expens	2,556.25	Annual Support Software Services 2024
534 10 48 00	Computer Support/Mainten		401 000 534 Water Operatin	2,556.24	Annual Support Software Services 2024
535 10 48 01	Computer Support/Mainten		405 000 535 Sewer Operatin	2,556.24	Annual Support Software Services 2024
537 10 41 01	Computer Support/Mainten		420 000 537 Solid Waste Fu	2,556.24	Annual Support Software Services 2024
16891	02/01/2024	02/01/2024	1584 STRIPE RITE INC.	526.94	Handicap Signage
594 76 63 01	2022 Paul Lauzier Grant - F		001 000 594 Current Expens	526.94	Handicap Signage
16888	02/01/2024	02/01/2024	2140 THINK TANK SANITATION INC.	340.00	Portable Restrooms
576 80 47 00	Park Utilities		001 000 576 Current Expens	340.00	Portable Restrooms

ACCOUNTS PAYABLE

City Of Mattawa

Time: 15:24:08 Date: 01/30/2024

As Of: 02/01/2024

Page: 3

Accts Pay #	Received	Date Due	Vendor	Amount	Memo	
16894	02/01/2024	02/01/2024	732	U.S CELLULAR	764.24	MPD Phone Cell Phone Services
	521 20 42 00 Telephone		001 000 521 Current Expens	764.24	MPD Phone Cell Phone Services	
16909	02/01/2024	02/01/2024	732	U.S CELLULAR	511.23	PW & Clerks/Mayor Cell Phone Services
	518 23 42 14 Telephone/Internet Expense		001 000 518 Current Expens	193.15	Clerks/Mayor Cell Phone Services	
	534 10 42 00 Telephone		401 000 534 Water Operatin;	105.98	PW Cell Phone Services	
	535 10 42 00 Telephone		405 000 535 Sewer Operatin	105.98	PW Cell Phone Services	
	537 10 42 00 Telephone		420 000 537 Solid Waste Fu	106.12	PW Cell Phone Services	
16910	02/01/2024	02/01/2024	2986	ULINE	1,332.00	PW- Supplies
	534 10 31 01 Operating Supplies		401 000 534 Water Operatin;	666.00	Reflective Traffic Cones	
	535 10 31 00 Office Supplies		405 000 535 Sewer Operatin	666.00	Reflective Traffic Cones	
16903	02/01/2024	02/01/2024	480	WA FINANCE OFFICERS ASSOCIATION	75.00	WFOA Membership Dues - Anabel
	514 23 49 02 Assoc. Dues/AWC		001 000 514 Current Expens	75.00	WFOA Membership Dues - Anabel	
16922	02/01/2024	02/01/2024	480	WA FINANCE OFFICERS ASSOCIATION	75.00	WFOA Membership Dues - Jazmin
	514 23 49 02 Assoc. Dues/AWC		001 000 514 Current Expens	75.00	WFOA Membership Dues - Jazmin	
16901	02/01/2024	02/01/2024	143	WA STATE DEPT OF ECOLOGY	3,194.90	Hydro Study Loan Re-Payment EL200395
	591 35 70 00 Hydro Study Re-Payment -		406 000 591 Sewer Debt Fur	2,163.83	Hydro Study Loan Re-Payment EL200395	
	591 35 79 00 Hydro Study Re- Payment -		406 000 591 Sewer Debt Fur	515.54	Hydro Study Loan Re-Payment EL200395	
	591 35 80 00 Hydro Study Re-Payment -		406 000 591 Sewer Debt Fur	515.53	Hydro Study Loan Re-Payment EL200395	
16896	02/01/2024	02/01/2024	2957	WASTE MANAGEMENT	67.44	WWTF Garbage Disposal
	535 10 47 00 Utilities		405 000 535 Sewer Operatin	67.44	WWTF Garbage Disposal	

Report Total: 35,032.16

Fund	
001 Current Expense Fund	13,123.49
107 Public Safety Tax Fund	2,481.70
401 Water Operating Fund	6,593.66
403 Customer Deposit Fund	100.00
405 Sewer Operating Fund	6,876.05
406 Sewer Debt Fund	3,194.90
420 Solid Waste Fund	2,662.36

ACCOUNTS PAYABLE

City Of Mattawa

Time: 15:24:08 Date: 01/30/2024
Page: 4

As Of: 02/01/2024

Accts
Pay # Received Date Due Vendor Amount Memo

This report has been reviewed by:

Anabel Martinez
Anabel Martinez - City Clerk

1/30/24
Date

REMARKS:



City of Mattawa
521 E Government Rd / P.O. Box 965
(509)932-4037
Mattawa WA. 99349

Event Permit
Ordinance 15-566

1. **Certificate of coverage** in the amount of two-million dollars combined –one-million per occurrence, two-million dollars aggregate, AND an **Endorsement** naming the City of Mattawa as an additional insured must be provided at the time of application. Please also include the policy # on both of these forms.
2. Fill out application & submit all paperwork to the city clerk at **least 45 days** prior to the date on which the event is to occur.
3. The park was developed for City of Mattawa residents to use for family outings, picnics and as a children's playground. It may also be used for events or social functions of City of Mattawa individuals, children, family and their guest or non-profit organization at little or no expense.
4. If the Police Department or Public Works in reviewing this application requires extra help to be in attendance then the applicant will reimburse the City of Mattawa for the cost including over time of Police personnel and/ or Public Works employees.
5. The applicant shall pay for all additional garbage cans and all additional portable toilets that are needed for this event.
6. In the event that City of Mattawa property is destroyed because of this event, then the applicant shall be billed and will pay for all costs of the repair (s).
7. The Mattawa Municipal Noise Ordinance and the applicable sections of the State Law will be enforced at all times.
8. Parking attendants may be required for large groups.
9. Licensed Security Company may be required at the event.
10. The fee for issuance of a special event permit shall be set by resolution of the city council.
11. Site Plan (if applicable)

Event Title: Silence procecion
procecion del silencio Event Date 3/29/2024

Summary of Event

silence procecion -

Location (be specific)

Our Lady of the Desert — see map →

DATE/TIME

Setup Date March/29/24 Time 6:00 pm Day of Week friday
Event Starts Date March/29/2024 Time 8:00 pm Day of Week friday
Event Ends Date March/29/2024 Time 9:30 pm Day of Week friday
Dismantle Date _____ Time _____ Day of Week _____

Estimated Attendance 200
Will there be a paid admission? Yes/ No
Is your event open to the public? Yes/ No

Applicant's Name Rev. lalo Barragan
Phone 509-932-5424

If Applicant is an organization, corporation, limited liability company, other entity please provide following additional information:

Name of organization/corporation/limited liability company or other entity: Our Lady of the Desert Parish - (catholic church)

Name and title of person signing on behalf of the organization/corporation/limited liability company or other entity:

Rev. Ialo Barragan

(This person must have the legal authority to sign and bind the organization, corporation, Limited Liability Company or other entity. Additional documentation may be required to confirm such signing authority if requested by the City.)

Applicant's Mailing Address

301 8th St Mattawa WA 99349

Applicant's Email

office@ourladyofthedesperitparish.org

Name of Applicant's On-Site Contact (to be available during event)

Rev - Ialo Barragan Matte

Phone Number of Applicant's On-Site Contact (to be available during event)

509-932-5424

Mark all that apply

- Alcohol
- Amplified Sound
- Animals
- Bleachers
- Boats
- Carnival Rides
- Company Picnic
- Concert/Live Music
- Cooking/Barbecue
- Distribution/Sales
- Drawing/Raffles
- Dunk Tank
- Electricity/Generator
- Entertainment
- Exhibits/Displays
- Fencing (temporary)
- Festival
- Fireworks
- Food
- P.A. System
- Race
- Rally/Protest
- Street Closures
- Signage/Banners
- Sporting Event
- Stage
- Vendors
- Tables/Chairs
- Tents/Canopies
- Vehicles
- Water
- Other _____
- Other _____
- Other _____
- Other _____

Provide details for all checked items and describe any "other" items. If there will be food or merchandise/vendors at event please indicate if food, merchandise or services will be provided free of charge or if they will be sold:

AVAILABLE FOR AN ADDITIONAL FEE (these items may be an event requirement.)

Garbage Disposal

Police Department Public Service

Public Work Public Service See Email

Office Usage Only

Anabel Martinez

From: Office OurLadyoftheDesert <office@ourladyofthedesertparish.org>
Sent: Monday, January 22, 2024 9:19 AM
To: Anabel Martinez
Subject: Correction on walking processions.

Follow Up Flag: Follow up
Flag Status: Completed

CAUTION: External Email

Good morning Anabel.

Making Correction for the following dates.

Palms Sunday, March 24, 2024. We are going to need street public works assistance for street closure. We will start at the park and will walk up Government RD - Selkirk - 8th St. finish start will be at the Catholic Church. Time: 10:45 am - 12:00 pm.

Same with Good Friday, March 29, 2024. Public Works assistance will be needed for street closure. Starting at the Catholic Church and going towards Portage-4th St-Selkirk Ave- 8th St. and will finish at the Church. Time: 8:00 pm - 9:30 pm.

We understand that there will be additional fees for the services.

Please let me know if there is anything else I need to do on my end.

Respectfully

Adriana Favela
509-932-5424
Office@ourladyof [thedesertparish.org](mailto:office@ourladyofthedesertparish.org)

Friday
March 12th / 2024
8pm - 9:30pm

Silence procession

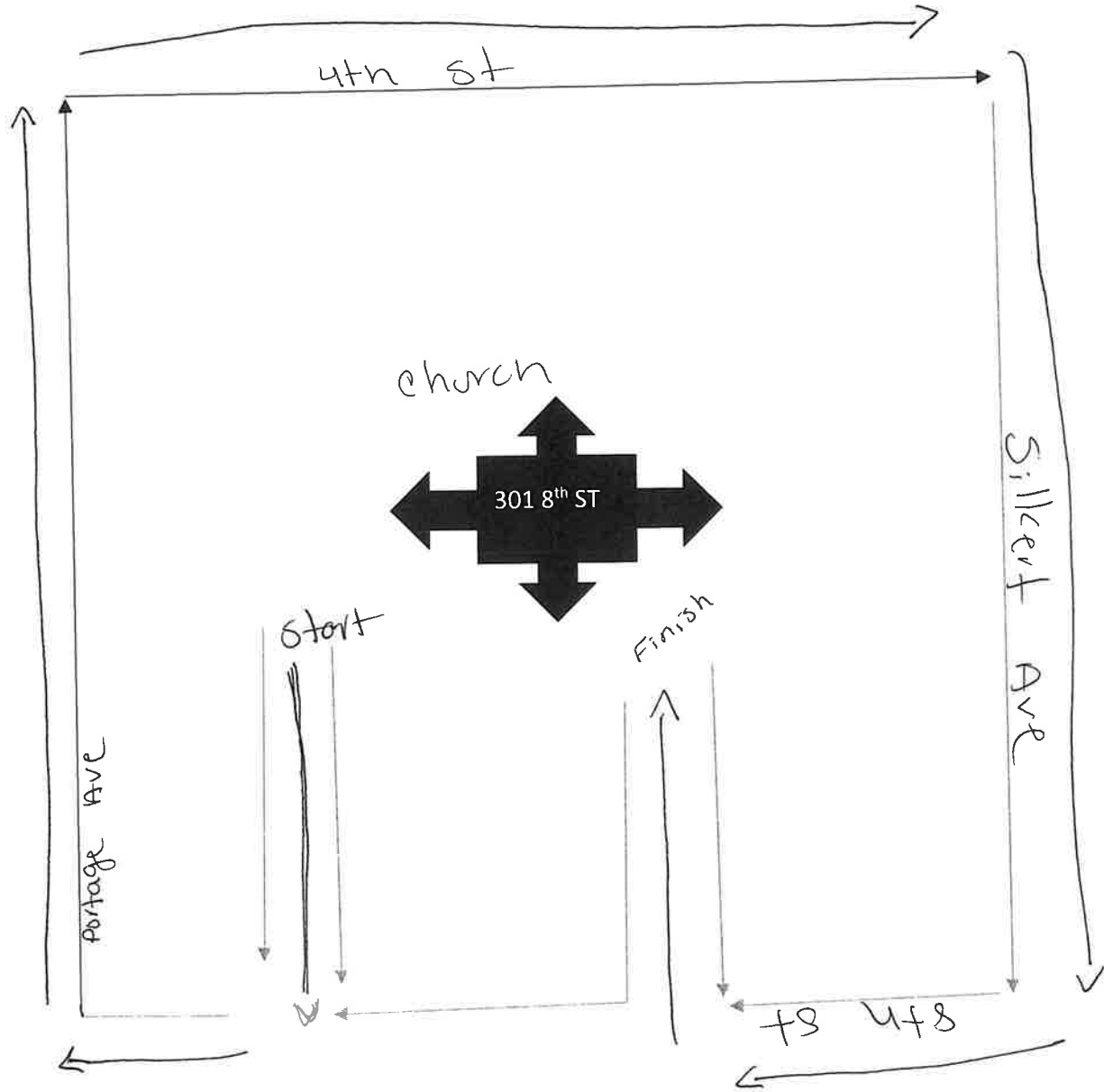

Certificate of Coverage

Date: 1/8/2024

Certificate Holder
 Corporation of the Roman Catholic Bishop of
 Yakima
 Chancery Office
 P.O. Box 2189
 101 South 12th Avenue
 Yakima, WA 98902

Covered Location
 Our Lady of the Desert
 301 E. 8th Street
 P.O. Box 1185
 Mattawa, WA 99349

This Certificate is issued as a matter of information only and confers no rights upon the holder of this certificate. This certificate does not amend, extend or alter the coverage afforded below.

Company Affording Coverage
 THE CATHOLIC MUTUAL RELIEF
 SOCIETY OF AMERICA
 10843 OLD MILL RD
 OMAHA, NE 68154

Coverages

This is to certify that the coverages listed below have been issued to the certificate holder named above for the certificate indicated, notwithstanding any requirement, term or condition of any contract or other document with respect to which this certificate may be issued or may pertain, the coverage afforded described herein is subject to all the terms, exclusions and conditions of such coverage. Limits shown may have been reduced by paid claims.

Type of Coverage	Certificate Number	Coverage Effective Date	Coverage Expiration Date	Limits
Property				Real & Personal Property
D. General Liability <input checked="" type="checkbox"/> Occurrence <input type="checkbox"/> Claims Made	8509	7/1/2023	7/1/2024	Each Occurrence
				2,000,000
				General Aggregate
				2,000,000
				Products-Comp/OP Agg
Excess Liability				Each Occurrence
				Annual Aggregate
Other				Each Occurrence
				Claims Made
				Annual Aggregate
				Limit/Coverage

Description of Operations/Locations/Vehicles/Special Items (the following language supersedes any other language in this endorsement or the Certificate in conflict with this language)
 Our Lady of the Desert's walking procession from Hunts Park to Our Lady of the Desert Parish on March 29, 2024, only with respect to liability for "bodily injury", "property damage", or "personal and advertising injury" caused in whole or in part, by our acts or omissions; the acts or omissions of those acting on our behalf. Coverage includes property damage under liability but only with respect to liability.

Holder of Certificate

Additional Protected Person(s)

City of Mattawa
 521 E. Government Road
 P.O. Box 965
 Mattawa, WA 99349

Cancellation

Should any of the above described coverages be cancelled before the expiration date thereof, the issuing company will endeavor to mail 30 days written notice to the holder of certificate named to the left, but failure to mail such notice shall impose no obligation or liability of any kind upon the company, its agents or representatives.

Authorized Representative

Michael A. Antunovic

0166003492

ENDORSEMENT

(TO BE ATTACHED TO CERTIFICATE)

Effective Date of Endorsement 3/29/2024 Charge _____ Credit _____
Cancellation Date of Endorsement 3/30/2024
Certificate Holder Corporation of the Roman Catholic Bishop of Yakima Chancery Office P.O. Box 2189 101 South 12th Avenue Yakima, WA 98902
Location Our Lady of the Desert 301 E. 8th Street P.O. Box 1185 Mattawa, WA 99349
Certificate No. 8509 of The Catholic Mutual Relief Society of America is amended as follows:

SECTION II - ADDITIONAL PROTECTED PERSON(S)

It is understood and agreed that Section II - Liability (only with respect to Coverage D - General Liability), is amended to include as an **Additional Protected Person(s)** the organization(s) shown in the schedule below.

Schedule - ADDITIONAL PROTECTED PERSON(S)

<p>City of Mattawa 521 E. Government Road P.O. Box 965 Mattawa, WA 99349</p> <p>Remarks: Our Lady of the Desert's walking procession from Hunts Park to Our Lady of the Desert Parish on March 29, 2024, only with respect to liability for "bodily injury", "property damage", or "personal and advertising injury" caused in whole or in part, by our acts or omissions; the acts or omissions of those acting on our behalf. Coverage includes property damage under liability but only with respect to liability.</p>

However, the following limitations apply to coverage:

1. The maximum limits of coverage provided by Catholic Mutual Relief Society of America to the **Additional Protected Person(s)** named in this endorsement shall not exceed the coverage dollar amount specifically required by contract or agreement and agreed to by the **Protected Person(s)**. In the absence of specific coverage limits within a referenced contract or agreement, the limits of liability afforded to the **Additional Protected Person(s)** must be listed on a separate Certificate of Coverage form attached to this endorsement. All limits of liability extended by this endorsement are inclusive of both Section II Coverage D and Section VII coverages (if applicable).
2. Unless specifically agreed to by contract or agreement, the coverage extended to the **Additional Protected Person(s)** by this endorsement is excess and non-contributory over any other available coverage or insurance.
3. This endorsement does not apply to any **Occurrence** outside the specific date(s) of a facility use agreement or terms of a lease.
4. This endorsement does not extend coverage to the **Additional Protected Person(s)** for **Occurrences** which cannot be attributed to primary acts or omissions of the **Protected Person(s)**.
5. Provided that a premises is utilized by the **Protected Person(s)** in a manner consistent with its intended purpose and in accordance with the applicable contract, agreement, or lease, this endorsement does not extend coverage to the **Additional Protected Person(s)** for premises defects or other **Occurrences** which could not be discovered by the **Protected Person(s)** with reasonable diligence.
6. The limited coverage afforded to the **Additional Protected Person(s)** by this endorsement only applies to the extent permissible by law and shall not apply to non-delegable duties unless specifically agreed to by contract or agreement.

This extension of coverage shall not enlarge the scope of coverage provided to the **Certificate Holder** under this Certificate nor increase the limit of liability thereunder. Unless otherwise agreed by contract or agreement, coverage extended under this endorsement to the **Additional Protected Person(s)** will not precede the effective date of this endorsement or extend beyond the cancellation date.

CITY OF MATTAWA

STAFF REPORT

To: Mayor Celaya and City Council
 From: Public Works Department
 Date: February 1, 2024
 Proceeding Type: New Business
 Subject: Amending Chapter 10.20

Legislative History:

- | | |
|------------------------|------------------|
| • First Presentation: | February 1, 2024 |
| • Second Presentation: | |
| • Requested Action: | Motion |

Staff Report Summary

The subject in front of City Council is to approve updating MMC 10.20.

Background

Subject was discussed in 2023, regarding heavy vehicles. New section MMC 10.20 was pending to be added (see attached).

Fiscal and Policy Implications

No financial impacts are expected besides overhead. Policy implications include updating the MMC.

FUND	BARS	LINE ITEM	AMOUNT BUDGETED	CURRENT EXPENDITURE	REMAINING BUDGET AMOUNT
TOTAL					

Options

1. Approve Ordinance 24-691.
2. Do not approve Ordinance 24-691; and stop snow plowing city roadways; inform the school district and Consolidate waste disposal of violation, etc.

Staff Recommendation

1. Approve updating MMC 10.20.

Attachments

A.	MMC 10.20.035 TITLED "CITY ARTERIALS AND RESIDENTIAL STREETS"
----	---

The following documents are attached and subject for review:

Review by:	Type of Document	Title of Document	Date Reviewed	Comment:
Engineering	▪ N/A	Staff Report		
Legal	▪ WORD	Ordinance 24-691	1/15/2024	
Financial	▪ PDF	Staff Report	1/26/24	Initials: <i>SKY</i>
Comment:				

ORDINANCE NO. 24-691

AN ORDINANCE AMENDING CHAPTER 10.20 “TRUCK REGULATIONS” TO ADD A NEW SECTION 10.20.035 TITLED “CITY ARTERIALS AND RESIDENTIAL STREETS”

The City Council of the City of Mattawa, Washington, do ordain as follows:

Section 1. Amended. Chapter 10.20 “Truck Regulations” is amended to add a new Section 10.20.035 of the Mattawa Municipal Code titled “City Arterials and Residential Streets” as follows:

10.20.035 City Arterials and Residential Streets.

The following trucks shall be permitted on city arterials and residential streets even though not designated as “through truck routes” and even though exceeding the combined axle load of 12,000 lbs:

- A. Commercial vehicles delivering merchandise to businesses and homes within the city limits.
- B. Utility vehicles servicing utilities within the city limits.
- C. Local garbage collector vehicles operating within the city limits.
- D. Construction vehicles may operate within the city limits; however, the owners shall be responsible for wheel rut repairs and/or other damage resulting to streets traveled by construction equipment to the City of Mattawa and as provided for in RCW 46.44.110 and 46.44.120.
- E. Municipal vehicles of the City of Mattawa.
- F. School buses.
- G. Vehicles approved by the city used in parades.
- H. Unloaded vehicles used for transportation by operators to their home. These vehicles may only be allowed on the streets for a maximum of four (4) hours.
- I. Trucks enroute to and from repair shops.
- J. Mail trucks.

Section 2. Effective Date. This ordinance shall be in full force and effect five days after passage and publication of its summary as provided by law.

PASSED BY THE CITY COUNCIL OF THE CITY OF MATTAWA THIS 1st DAY OF FEBRUARY 2024.

Maggie Celaya, Mayor

ATTEST:

Anabel Martinez, City Clerk

APPROVED AS TO FORM:

Katherine L. Kenison, City Attorney

PASSED the 1ST day of February 2024.

APPROVED the 1st day of February 2024.

PUBLISHED the 7th day of February 2024.

CITY OF MATTAWA

STAFF REPORT

To: Mayor Celaya and City Council
 From: Public Works Department
 Date: February 8, 2024
 Proceeding Type: New Business
 Subject: Updating 2018 Construction Standards

Legislative History:

- | | |
|------------------------|------------------|
| • First Presentation: | February 8, 2024 |
| • Second Presentation: | |
| • Requested Action: | Motion |

Staff Report Summary

The subject in front of City Council is to approve updating the City's Construction standards.

Background

The City Developer Standards/ Construction Standards were updated in 2018 and revised in 2020. Due to new City construction needs and comments from DOH the City's existing construction standards require updates.

Fiscal and Policy Implications

Financial impacts are listed in G&O amendment no.5 in 2023 and had a not-to-exceed \$3,000 scope of work budget. Policy implications include updating the Construction Standards.

FUND	BARS	LINE ITEM	AMOUNT BUDGETED	CURRENT EXPENDITURE	REMAINING BUDGET AMOUNT	

Options

1. Approve the update of the City's Construction standards.
2. Do not approve the update of the City's Construction standards.

Staff Recommendation

1. Approve the update of the City's Construction standards.

Attachments

A.	Spec's / Sections to updated
----	------------------------------

The following documents are attached and subject for review:

Review by:	Type of Document	Title of Document	Date Reviewed	Comment:
Engineering	▪ PDF	Staff Report	1/29/24	
Legal	▪ N/A			
Financial	▪ WORD	Staff Report	1/26/2024	Initials: <i>Jey</i>
Comment:				

CITY OF MATTAWA

GRANT COUNTY

WASHINGTON



2018 CONSTRUCTION STANDARDS

Revision 1
March 3, 2020

G&O #17020



Gray & Osborne, Inc.
CONSULTING ENGINEERS

CHAPTER 1
GENERAL REQUIREMENTS

REQUIREMENTS FOR DEVELOPER CONSTRUCTED IMPROVEMENTS

Section A: General Provisions

1. The specifications and standard details provided herein shall be used to implement design and construction requirements of the City of Mattawa development ordinances, codes, or titles. The use of product manufacture names or trademarks is intended to provide examples of acceptable quality standards. Parts or products specified by name may be interchangeable with like and equal products only upon prior City approval.
2. Definitions for terms described herein shall be those provided pursuant to Title 13 of the Mattawa Municipal Code. The definition of any word or phrase which may not be identified pursuant to Title 13 shall be defined from either one of the following sources:
 - A. Revised Code of Washington.
 - B. Washington Administrative Code.
 - C. Commonly used dictionary such as Merriam-Webster's.
3. Within this document are numerous references to "the City". All communication with the City shall be first directed to the City of Mattawa Public Works Director. The Public Works Director may designate an alternate contact for specific items, however only the Public Works Director shall have the authority to provide approval for variations from this document.

Section B: General Requirements of the Developer

1. The Developer shall retain the services of ~~an engineer registered with a~~ [Professional Engineer licensed in](#) the state of Washington to provide necessary construction design services.
2. Complete plans and specifications of any proposed improvement shall be submitted to the City for approval. Upon City review and approval, the Developer shall submit all water and sewer plans and specifications to the Departments of Health and Ecology.
3. Unless otherwise approved by the City, plan and design drawings shall have a minimum scale of 1 inch equal to 50 feet, or, 1 inch equal to 40 feet if water, sewer, and street improvements are drawn on the same sheets.

4. All utilities, whether City-owned or provided by an outside purveyor, shall be placed within the City's required right-of-way.
5. Water and sewer certification shall be on standard State forms. Copies of testing data including, but not limited to, compaction and pressure testing, shall be provided to the City. Street certification shall consist of a letter, test data, weigh tickets, and other associated or City required information.
6. The Developer shall provide a performance bond or similar security instrument to ensure workmanship and materials over the full time period between project beginning and end.
7. The Developer shall require the Contractor to provide insurance which insures all contracted work and which holds the City and its agents harmless from any and all damage claims which may result due to the performance of any contracted work. The Contractor shall provide the City proof of insurance which shall be approved by the City prior to commencing contracted work.
8. The Developer shall provide the City with a mylar copy of construction record drawings illustrating all revisions made during construction. At minimum, the record drawings shall show the following:
 - A. The existence of all underground utilities encountered (station and depth).
 - B. Precise distance to fittings, valves, services, etc, length of all spools, etc.
 - C. Type of all fitting ends (MJ, FL, etc.).
 - D. Type of restraint used.
 - E. Location of sewer wyes.
 - F. Elevation of each manhole, pipe invert (in and out) and sewer slope.
9. Where specific manufacturers are required for facilities and materials, installation of those facilities and materials shall be completed to the manufacturer's specifications, unless otherwise approved by the City.
10. No excavation work shall be done between November 15 and February 15 without permission from Mattawa Public Works.
11. Water system improvements shall meet the requirements of the Washington State Department of Health Water System Design Manual, current edition, and the specifications as described herein.

12. Sewer system improvements shall meet the requirements of the Washington State Department of Ecology Criteria for Sewerage Works Design, current edition, and the specifications as described herein.
13. The storm drainage standards established herein are intended to represent the minimum standards for the design and construction of storm drainage facilities. Greater or lesser requirements may be mandated by the City due to localized conditions. Storm drainage revisions, additions, modification, or changes shall be made in compliance with City standards, ordinances, and Best Management Practices as identified in the Washington State Department of Ecology Stormwater Management Manual for Eastern Washington, hereinafter referred to as "Stormwater Manual." Adequate provisions shall be made for storm drainage, storm sewers, and associated appurtenances sufficient to transmit maximum runoff from the 25-year, 24-hour event. All storm drainage facilities shall be designed by a professional engineer licensed in the State of Washington and shall comply with the Stormwater Manual.

If warranted based on the condition and capacity of the existing storm drainage infrastructure (or lack thereof) and impacts caused by the proposed development, off-site improvements may be required, at the City Engineer's discretion, to mitigate impacts caused by the proposed development.

END CHAPTER 1

CHAPTER 5
STREETS

ST-1 EXCAVATION AND SUBGRADE PREPARATION

Existing material shall be excavated and hauled from the project site as necessary to accommodate the proposed finished grade and roadway section. If the subgrade is disturbed during excavation, the subgrade shall be compacted prior to placing new roadway material.

Unsuitable subgrade materials, including but not limited to: unstable or soft soils such as peat, muck, and clay; roots, buried logs, buried stumps, garbage, or other debris shall be excavated and hauled from the project site. Unsuitable foundation excavation shall be replaced with Gravel Borrow. If needed to stabilize soft material, the excavation shall be lined with construction geotextile for separation before placing gravel borrow.

Construction Geotextile for Separation shall conform to the material requirements of Section 9-33 of the WSDOT Standard Specifications.

Gravel Base shall conform to the material requirements of Section 9-03.10 of the WSDOT Standard Specifications.

ST-2 ROADWAY CONSTRUCTION

New roadway construction (including full width construction, partial width construction, and patching) shall consist of a crushed surfacing and pavement as shown in the Details.

Roadway edges shall consist of a 6-foot-wide, 4-inch compacted depth Crushed Surfacing Top Course shoulder or cement concrete curb, gutter, and sidewalk. Roadway signs shall be placed in accordance with WSDOT Standard Plan G-20.10-02.

Pavement joints shall consist of neat line sawcut edge and shall receive a tack coat prior to paving. Apply asphalt paving sealant to joints.

Asphalt thickened edge and asphalt berms shall be constructed of Commercial HMA along a straight, neat line, and shall be graded to drain. If constructed after wearing course is in place, joints shall be sealed with paving asphalt.

Paved surfaces intended for use as pedestrian walkways shall be constructed in accordance with the requirements for slope, grade, dimensions, and surface smoothness, and other criteria set forth by the Americans with Disabilities Act (ADA) and detailed in the WSDOT Field "Guide for Accessible Public Rights of Way" and the United States Access Board "Proposed Accessibility Guidelines for Pedestrian Facilities in the Public Right-of-Way."

Crushed Surfacing Base Course shall conform to the construction and material requirements of Section 4-04 of the WSDOT Standard Specifications.

Commercial HMA shall conform to the construction and material requirements of Section 5-04 of the WSDOT Standard Specifications.

Bituminous Surface Treatment shall conform to the construction and material requirements of Section 5-02 of the WSDOT Standard Specifications.

ST-3 CONCRETE CURBS AND PEDESTRIAN FACILITIES

All pedestrian facilities shall be constructed in accordance with the requirements for slope, grade, dimensions, and surface smoothness, and other criteria set forth by the Americans with Disabilities Act (ADA) and detailed in the WSDOT "Field Guide for Accessible Public Rights of Way" and the United States Access Board "Proposed Accessibility Guidelines for Pedestrian Facilities in the Public Right-of-Way"

Cement Concrete Curb and Gutter, Cement Concrete Pedestrian Curbs, and other curbs including extruded curb shall conform to the construction and material requirements of Section 8-04 of the WSDOT Standard Specifications.

Cement Concrete Driveway Entrances shall conform to the construction and material requirements of Section 8-06 of the WSDOT Standard Specifications.

Cement Concrete Sidewalks and Cement Concrete Curb Ramps shall conform to the construction and material requirements of Section 8-14 of the WSDOT Standard Specifications.

ST-4 STREET CLASSIFICATIONS

The classifications of all streets shall be established by the Public Works Department. Street changes in classifications shall be shown to meet the following criteria. Refer to the Standard Details at the end of this section.

LOCAL ACCESS STREET: A short street, cul-de-sac, court or a street with branching places or lanes. A Local Access Street is a minor residential street, and usually there is not through traffic between two streets of a higher classification. The ADT (Average Daily Traffic) can reach up to 1500. Local access streets are only allowed upon approval from the Public Works Department. Face of curb radii's shall be to the lowest street classification of the intersection and shall be a minimum 25' radius on Local Access Streets. Street centerline radii shall be designed to a minimum 30 mph design speed or as approved by the City. Sidewalks shall be required on Local Access streets where designated by the City.

COLLECTOR: The Collector is a secondary street in the urban system and correspondingly has the second highest average daily traffic (ADT). The Collector generally receives many vehicles from Local Streets and/or is the major route to significant activity centers. Collector streets should not generally be encumbered with stop signs. The ADT (Average Daily Traffic) can exceed 1500+. Face of curb radii's shall be to the lowest street classification of the intersection and shall be a minimum 25' radius on Collector Streets. Street centerline radii shall be designed to a minimum 35 mph design speed or as approved. Collectors shall be further defined by the location and types of generators served. Collectors serving primarily commercial or industrial areas shall be classified as Major Collectors. Collectors serving primarily residential areas shall be classified as Minor Collectors.

ARTERIAL: Arterial streets contain the greatest proportion of through travel. Such facilities serve the high-volume travel corridors that connect the major generators of traffic. Arterials typically connect with collectors that extend into the urban area. Face of curb radii's shall be to the lowest street classification of the intersection and shall be a minimum 30' radius on Arterial Streets. Street centerline radii shall be designed to a minimum 25 mph design speed or as approved by the City. Arterials shall be further defined by the location and types of generators served. Arterials serving primarily commercial or industrial areas shall be classified as Principal Arterials. Arterials serving primarily residential areas shall be classified as Minor Arterials.

* In extreme situations, with consent of the City and with possible parking restrictions as determined by the City, the width of roadway may be reduced. This reduction may only take place in situations where major utilities or streams, etc., are in conflict with improvements. Sidewalks and other roadway features may be required to be located at a location suitable for ultimate build-out.

** Centerline striping will be performed for Arterial and major Collector streets only (See street classification map) and as required by the MUTCD Manual.

ST-5 STREET LIGHTING

Poles, luminaires, and installation shall comply with Grant County Public Utility District (GCPUD) requirements and shall be coordinated with the City. The City shall have authority to designate pole and luminaire selection and installation in

accordance with GCPUD standards. Lighting levels shall conform to WSDOT Design Manual guidelines.

END CHAPTER 5

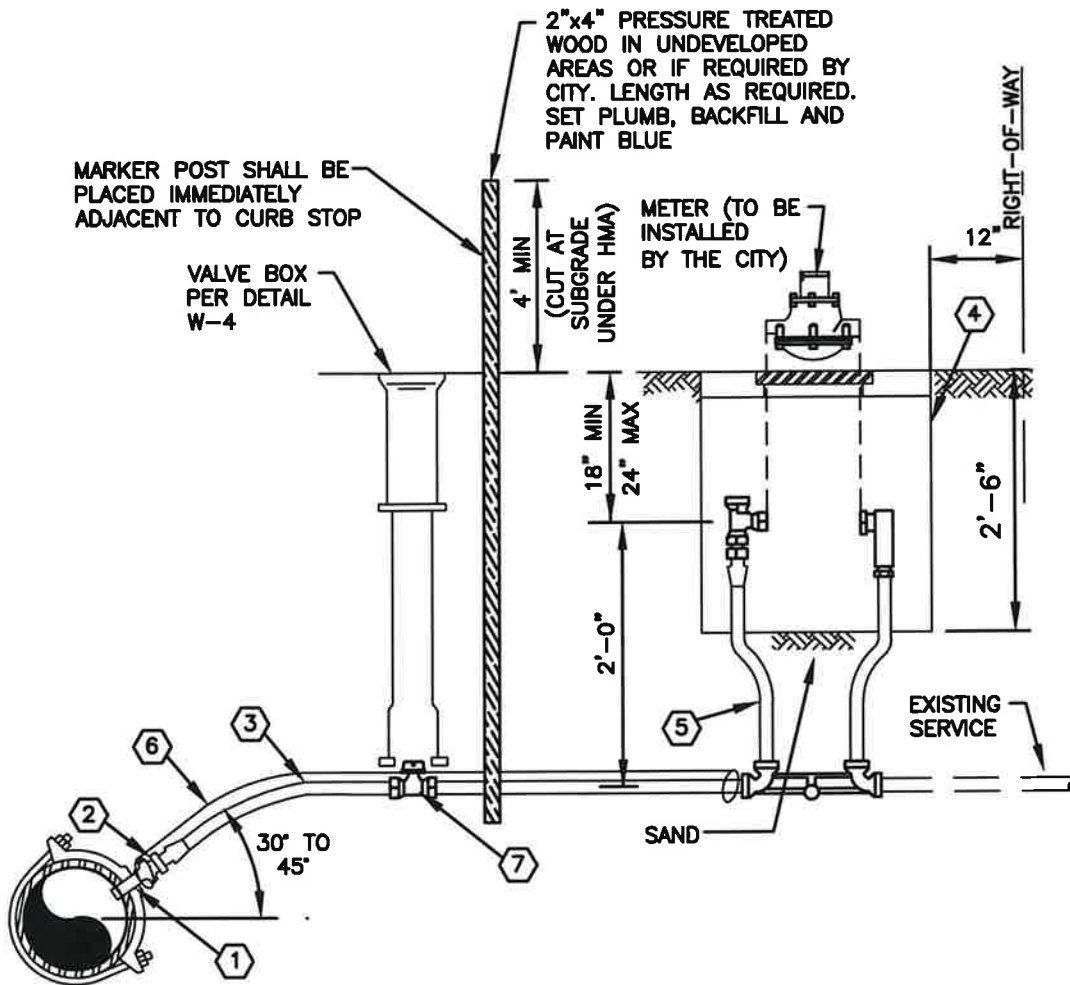

- ① FORD DOUBLE STRAP SERVICE SADDLE.
- ② CORPORATION STOP MUELLER H-15008.
- ③ 1" HDPE SERVICE PIPE - LENGTH AS REQUIRED (CTS 250 PSI)
- ④ BROOKS 12" X 20" METER BOX WITH H-20 RATED CAST IRON COVER.
- ⑤ FORD 70 SERIES COPPERSETTER, WITH ANGLE BALL AND SINGLE CHECK VALVE OR APPROVED EQUAL.
- ⑥ 14 GAUGE TRACER WIRE.
- ⑦ FORD BALL VALVE CURB STOP WITH PACK JOINTS, B44-444-NL. LOCATE AS DIRECTED BY CITY.

NOTES

1. SERVICE FROM METER BOX TO HOUSE BY PROPERTY OWNER.
2. INDIVIDUAL SERVICES REQUIRED FOR EACH LOT.
3. METER TO BE INSTALLED BY THE CITY AT OWNER'S EXPENSE.
4. COMPARABLE "FORD" FITTINGS MAY BE USED IN LIEU OF "MUELLER."



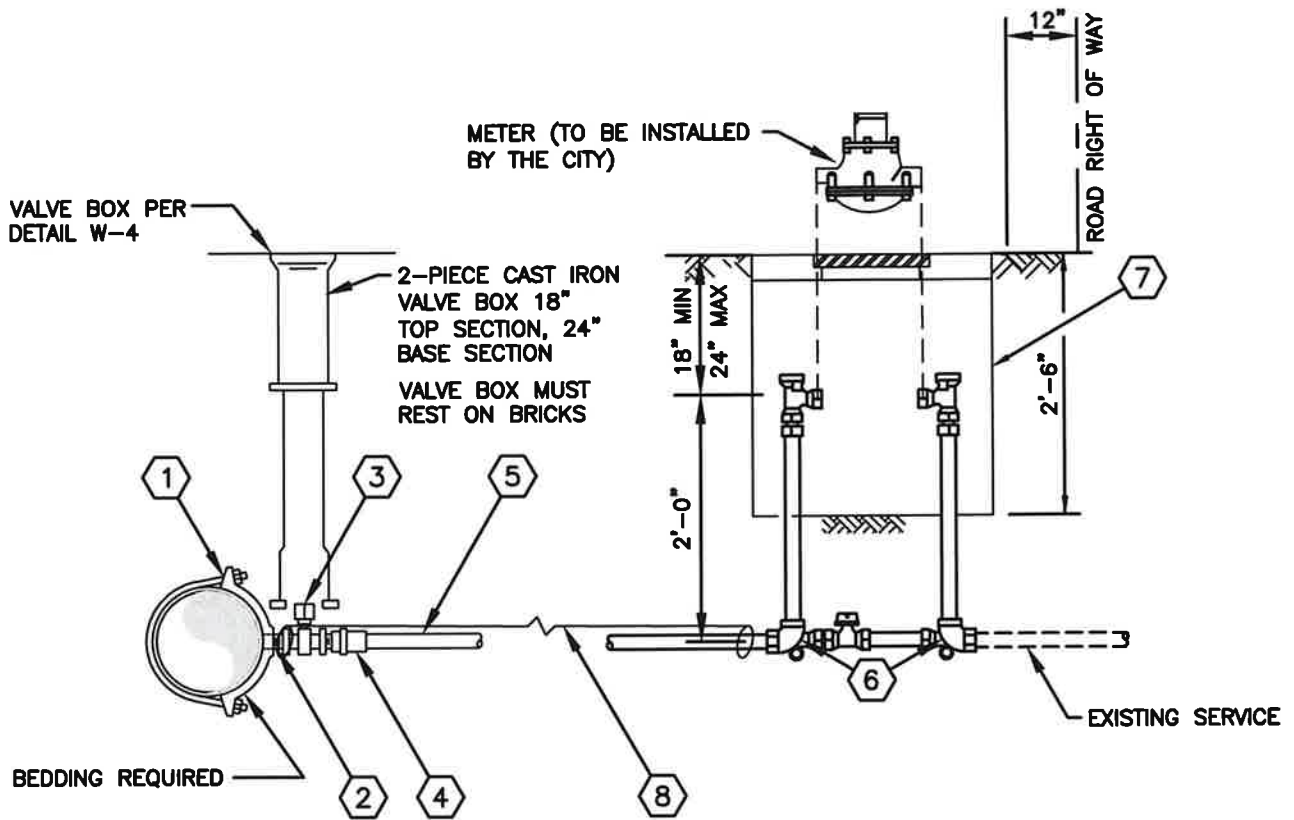

- ① FORD DOUBLE STRAP SERVICE SADDLE
- ② BRASS NIPPLE (3" MIN/6" MAX)
- ③ MUELLER B-20283 BALL VALVE WITH FORD OPERATING NUT ADAPTER QT-67
- ④ STRAIGHT COUPLING MUELLER H-15428 COMPRESSION x MIP
- ⑤ 1-1/2" OR 2" HDPE SERVICE PIPE - LENGTH AS REQUIRED (CTS 250 PSI)
- ⑥ FORD 70 SERIES COPPERSETTER WITH BALL VALVE INLET AND OUTLET
- ⑦ BROOKS 17"x30" METER BOX WITH H-20 RATED CAST IRON COVER
- ⑧ 14 GAUGE TRACER WIRE

NOTES:

1. SERVICE FROM METER BOX TO HOUSE BY PROPERTY OWNER INDIVIDUAL SERVICES REQUIRED FOR EACH PROPERTY.
2. METER TO BE INSTALLED BY THE CITY AT THE OWNER'S EXPENSE.
3. COMPARABLE "FORD" FITTINGS MAY BE USED IN LIEU OF "MUELLER."



FIGURE W-9
1-1/2" OR 2" WATER SERVICE

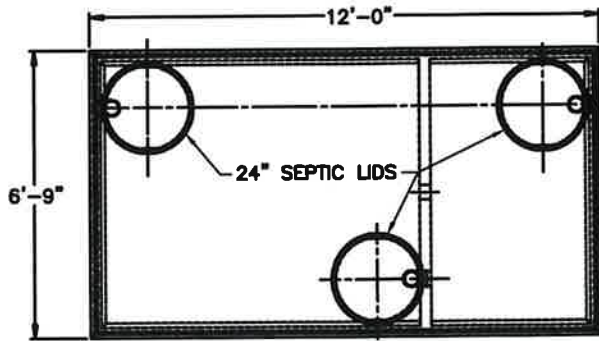

CONCRETE:
TANK CONSTRUCTION UTILIZES 4000 PSI
CONCRETE AND GRADE 60 REBAR.

REINFORCEMENT:
#4 BARS @ 6" OC EA WAY U-BARS IN TOP
(2) - #4 EACH SIDE OF ACCESS
#4 BARS @ 6" OC EA WAY IN SIDES
#4 BARS @ 6" OC EA WAY U-BARS IN BOTTOM

RISERS:
PVC: Ø24" & FIBER COVER (TO GRADE)
CONCRETE: Ø24" x 8" OR 12" (6" BELOW GRADE)

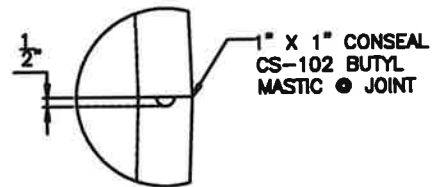
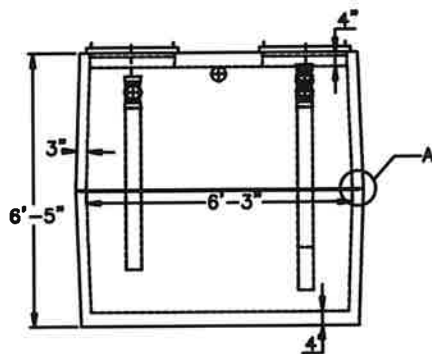
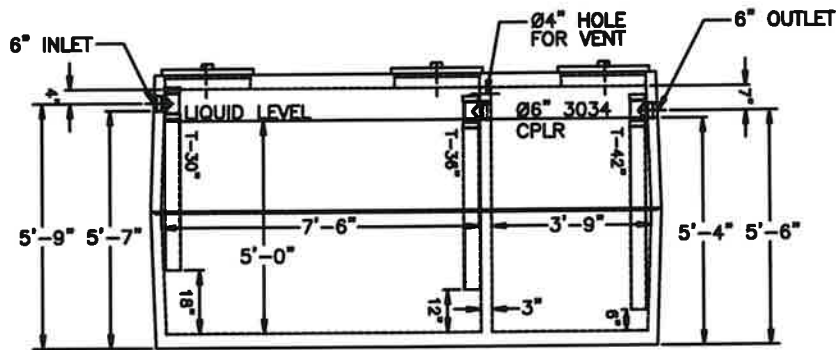

JOINT DETAIL A

NOTES:

1. GREASE INTERCEPTOR SIZE SHALL BE COORDINATED WITH AND APPROVED BY THE CITY.
2. GREASE INTERCEPTOR SHALL BE H-20 TRAFFIC RATED AS REQUIRED BY THE CITY.

