

Valley County Board of County Commissioners

PO Box 1350 • 219 N Main Street
Cascade, Idaho 83611-1350



Phone (208) 382-7100
Fax (208) 382-7107

ELTING G. HASBROUCK
Chairman of the Board
ehasbrouck@co.valley.id.us

DAVID H. BINGAMAN
Commissioner
dbingaman@co.valley.id.us

SHERRY MAUPIN
Commissioner
smaupin@co.valley.id.us

DOUGLAS A. MILLER
Clerk
dmiller@co.valley.id.us

**IN THE OFFICE OF THE VALLEY COUNTY BOARD OF COMMISSIONERS
CASCADE, IDAHO
December 7, 2020**

**PRESENT: DAVE BINGAMAN (COMMISSIONER)
 SHERRY MAUPIN (COMMISSIONER)
 ELTING HASBROUCK (CHAIRMAN)
 DOUGLAS MILLER (CLERK)**

Commissioner, Dave Bingaman led the Pledge of Allegiance.

Chairman Hasbrouck presented the commissioners' agenda for December 7, 2020. Commissioner Maupin made a motion to approve the commissioners' agenda for December 7, 2020. Commissioner Bingaman seconded the motion. No further discussion, all in favor. Motion passed to approve the commissioners' agenda for December 7, 2020.

Chairman Hasbrouck presented the commissioner meeting minutes from November 23, 2020 and November 30, 2020. Commissioner Bingaman made a motion to approve the commissioner meeting minutes from November 23, 2020 and November 30, 2020. Commissioner Maupin seconded the motion. No further discussion, all in favor. Motion passed to approve the commissioner meeting minutes from November 23, 2020 and November 30, 2020.

Commissioner Maupin discussed the Valley County local housing site/soil evaluation and seasonal groundwater monitoring with Crestline Engineering. Commissioner Maupin advised that after an initial analysis of the proposed site it was discovered that there were issues with area and would not be conducive for allowing septic systems to be installed. Commissioner Maupin made motion to table signing an agreement with Crestline Engineering. Commissioner

Bingaman seconded the motion. No further discussion, all in favor. Motion passed to table signing an agreement for site/soil evaluation with Crestline Engineering.

Road Superintendent, Jeff McFadden presented the Blue Line Maps and provided an overview of the roads that had been included to the Blue Line Maps. Commissioner Bingaman made a motion to approve the Blue Line Maps as presented. Commissioner Maupin seconded the motion. No further discussion, all in favor. Motion passed to approve the Blue Line Maps as presented by Road Superintendent, Jeff McFadden.

Planning & Zoning Administrator, Cynda Herrick presented on a withdraw of an appeal of a Planning & Zoning Approval of Blackhawk on the River final plat and provided an explanation of the initial appeal. She recommended that the commissioners accept the withdraw of the appeal. Commissioner Maupin made a motion to accept the withdraw of the appeal of the Planning & Zoning Approval of Blackhawk on the River Final Plat. Commissioner Bingaman seconded the motion. No further discussion, all in favor. Motion passed to accept the withdraw of the appeal of the Planning & Zoning Approval of Blackhawk on the River Final Plat.

Planning & Zoning Administrator, Cynda Herrick presented on variance V-3-20 RMC Flagpole and provided the commissioners with a staff report. She also presented on the findings of facts and conclusions. She advised that the Valley County Planning & Zoning Commission approved the variance with conditions. The commissioners had the opportunity to ask staff questions regarding to variance. Commissioner Maupin and Commissioner Bingaman voiced concerns about the variance request but advised that they would not go against the recommendations of the Valley County Planning & Zoning Commissions. Commissioner Maupin made a motion to approve the variance for the RMC Flagpole with the conditions recommended by the Valley County Planning & Zoning Commission. Commissioner Bingaman seconded the motion. No further discussion, all in favor. Motion passed to approve the variance for the RMC Flagpole with the conditions recommended by the Valley County Planning & Zoning Commission.

Executive Director, Russ Duke from District IV Central District Health presented to the commissioners. He wanted to make a formal presentation to the commissioners and allow the commissioners to ask any general questions to the commissioners. He explained that within District IV there has been a significant amount of increased COVID-19 cases and provided an overview of steps that individuals need to take if they test positive for COVID. He advised that Central District Health was behind on the data entry and getting assistances from the Idaho National Guard. He advised that there was an increase of cases in Valley County and they are taking steps from the local hospitals to get overwhelmed. He reported that the states around Idaho are already overwhelmed and they are requesting that the State of Idaho not send any patients. Mr. Duke advised that the District IV Central District Health have issued a public health advisory for COVID and discussed the health advisory. He advised that he had been directed by the District IV Central District Health to create an order regarding COVID-19 restrictions. He discussed the impact of the order on local school districts including extracurricular activities. Mr. Duke discussed the difference between the District IV Central District Health Advisory and District IV Central District Health Public Order. He explained that if an order was in place and violated it was possible that a misdemeanor citation could be issued by local law enforcement. He explained that an order was currently in place in the City of Boise. Commissioner Maupin provided her opinion regarding the existing mandate and the enforcement component. Ms. Suzanne Mack provided her feedback to the commissioners and discussed the enforcement

component. Mr. Duke discussed that Central District Health was doing what it could to protect the individuals within the community. The commissioners had the opportunity to provide their opinion regarding mandates and enforcements. Sheriff, Patti Bolen informed the commissioners how they would handle enforcement if there was an order issued by District IV Central District Health. Ms. Suzanne Mack advised that her concerns about the morbidity and the impact on the medical providers. She further discussed quarantine recommendations and the impact that it has on individuals. Mr. Duke described the proposed orders and advised that it was not much different than what was already in place. He advised that the Central District Health wants to develop some consistency. He believed that the communities could work together to reduce the cases of COVID-19. He advised that the hospitals have significantly been impacted. Mr. Duke discussed the increase of COVID-19 cases and he discussed the observations of Central District Health and why they are recommending that the orders be in place. He discussed the Central District Health Board meeting that was scheduled for December 8, 2020, and the importance of the decision that would be made by the District IV Central District Health Board. Mr. Duke also presented on the COVID-19 vaccine roll out but advised that there was not enough to provide even to all medical providers. Mr. Duke was asking the support of the Valley County Board of Commissioners to support the recommended orders by District IV Central District Health. Mr. Scott Turlington with Tamarack Resort provided his opinion to the commissioners regarding the proposed Central District Health and advised that they would be supportive. He submitted a letter to the commissioners on behalf of Tamarack Resort. Mr. Duke provided a description of the proposed District IV Central District Health order and the existing mask mandate that was currently in place. He discussed the new proposed order and what counties it would impact. He advised that the orders could be lifted by District IV Central District Health. It was explained that the existing mandate could be enforced by misdemeanor citation. The commissioners suggested future clarifications regarding to the proposed order. Mayor of Cascade, Judy Nissula provided her input to the commissioners regarding getting all the business in the City of Cascade to comply with the proposed order. She requested an outreach to the local business to continue to educate the general public and businesses. District IV Central District Health concluded the presentation to the commissioners.

Chairman Hasbrouck opened the public hearing for CA-20-03 regarding General Development Standards and Code Amendments at 11:05 a.m. and asked if there was any conflict of interest or ex-parte communication. All commissioners advised that there was not any conflict of interest. Commissioner Maupin advised that she did attend a few of the general meetings regarding the code amendments.

Chairman Hasbrouck asked to hear a staff report. Ms. Diane Kushlin representing the City of McCall provided a staff report to the commissioners regarding the proposed General Development Standards and Code Amendment application to codify the existing McCall Area Design Guidelines and to amend the existing Development Standards for McCall City Limits and Impact Area Code Title 3.

McCall Community & Economic Develop Coordinator, Michelle Groenevelt also provided a staff report to the commissioners. The commissioners had the ability to ask questions to Ms. Groenevelt.

McCall City Planner, Morgan Bessaw also addressed the commissioners and answered questions from the commissioners.

Ms. Diane Kushlin continued reviewing the proposed changes to the existing development standards for the McCall City Limits and Impact area. The commissioners again asked questions to the proposed changes and Ms. Kushlin responded accordingly.

Ms. Michelle Groenevelt advised that the McCall City Council did not have enough time to vote on the proposed changes/amendments and would rehear the matter on December 17, 2020.

Chairman Hasbrouck asked to hear from any proponents. The record will reflect that no one presented to the commissioners as a proponent.

Chairman Hasbrouck asked to hear from undecided. The record will reflect that no one presented to the commissioners as an undecided participant.

Chairman Hasbrouck asked to hear from opponents. The record will reflect that no one presented to the commissioners as an opponent.

The commissioners tabled the Public Hearing CA-20-03 until December 21, 2020.

Boise National Forest District Ranger, Jake Strohmeyer conducted a presentation to the commissioners related to matters that had been done by the Boise National Forest. He discussed a few projects that had been conducted or planned for on the Boise National Forest. He informed the commissioners about the fire season across the nation including in the State of Idaho and presented on the Buck Horn fire which burned approximately 20,000 acres. He discussed the additional fire mitigation work that had been conducted in the area. He advised that they have a great vegetation plan for the next five to eight years with a NEPA completed for the work to be done. He provided an overview of the office hours and staffing for the office in Cascade due to the COVID-19 pandemic. He explained that that the bypass was completed for the snow grooming trail on No Business. Recreation Director, Larry Laxson asked about the Clear Creek Project and wanted to know when it would be completed. District Ranger Strohmeyer advised that the project would not start for at least another two years.

Chairman Hasbrouck presented the FY21 Annual Operating Plan with the Boise National Forest for the Snowmobile Trail Grooming Program. Commissioner Bingaman made a motion to approve the FY21 Annual Operating Plan with the Boise National Forest for the Snowmobile Trail Grooming Program. Commissioner Maupin seconded the motion. No further discussion, all in favor. Motion passed to approve the FY21 Annual Operating Plan with the Boise National Forest for the Snowmobile Trail Grooming Program.

Commissioner Maupin made a motion to go into Executive Session per Idaho Code 74-206 1(b)-“to consider the evaluation dismissal or disciplining of, or to hear complaints or charges brought against, a public officer, employee, staff member or individual agent, or public school student”-Personnel. Commissioner Bingaman seconded the motion. No further discussion, all in favor. Motion passed to go into Executive Session per Idaho Code 74-206 1(b)-Personnel at 11:54 a.m.

Chairman Hasbrouck brought the commissioners out of Executive Session per Idaho Code 74-206 1(b)-“to consider the evaluation dismissal or disciplining of, or to hear complaints or charges brought against, a public officer, employee, staff member or individual agent, or public school

student"-Personnel at 12:20 p.m. No decision was made after the Executive Session per Idaho Code 74-206 1(b)-Personnel.

The commissioners recessed for lunch at 12:21 p.m.

The commissioners returned from lunch at 1:00 p.m.

Chairman Hasbrouck presented Ms. Laurie Fedrick with a service award for 15 years of service with Valley County.

Treasurer, Gabe Stayton presented cancellation of Property Taxes for #21-1 through #21-19. He presented on the first one #21-1 and explained that the request was from the property tax owner. He provided an overview of the request. Chairman Hasbrouck made a motion to require the property tax owner to pay half of the interest and penalties. Commissioner Maupin seconded the motion. No further discussion, all in favor. Motion passed to require the property tax owner to pay half of the interest and penalties and cancel the remaining amount that was owed.

Treasurer Stayton presented on property Tax Cancellations #21-2 through 21-3. Commissioner Maupin made a motion to remove solid waste fees and residential solid waste fees for Tax Cancellation #21-2 through 21-3. Commissioner Bingaman seconded the motion. No further discussion, all in favor. Motion passed to remove solid waste fees and residential solid waste fees for Tax Cancellation #21-2 through 21-3.

Treasurer Stayton presented on property Tax Cancellation #21-4 through #21-19. Commissioner Maupin made a motion to approve Tax Cancellation #21-4 through #21-19. Commissioner Bingaman seconded the motion. No further discussion, all in favor. Motion passed through Tax Cancellation #21-4 through #21-19.

Commissioner Maupin began the discussion regarding the possibility of having a joint meeting with the McCall City Council to discuss the endowment lands. Commissioner Bingaman provided an overview of the next steps that would be taking place by Idaho Department of Lands. He suggested that the Valley County Board of Commissioners meet directly with Dustin Miller of the Idaho Department of Lands to schedule a time on the commissioners' agenda.

Chairman Hasbrouck opened the Public Hearing Ordinance at 1:42 p.m. Commissioner Bingaman made a motion to bring Ordinance 21-02 Snowmobile Ordinance back to the table. Commissioner Maupin seconded the motion. No further discussion, all in favor. Motion passed to bring Ordinance 21-02 Snowmobile Ordinance back to the table.

Planning & Zoning Administrator, Cynda Herrick provided an updated staff report to the commissioners regarding additions that had been made to Ordinance 21-02.

Prosecuting Attorney, Carol Brockmann provided an overview of the legal work that the Prosecuting Attorney's Office had conducted regarding Anderson Creek and advised that Mr. Paul Fitzer had agreed to assist the county regarding the easements in Anderson Creek. The commissioners discussed if they should have Anderson Creek back to the proposed Ordinance 21-02. The consensus was that they would not include Anderson Creek to the Ordinance 21-02 currently but would potentially add the area later.

Board of County Commissioners Meeting

December 7, 2020

Page 5

Planning & Zoning Administrator, Cynda Herrick discussed potential formatting of the ordinance.

Mr. Kimbell Gorley council of record for Aspen Holdings presented to the commissioners and the primary concern regarding Anderson Creek Road and the impact that it would have if the commissioners add Anderson Creek Road to the ordinance in the future.

Mr. Ed Priddy who owns property in Anderson Creek Road presented on an easement that he claimed property in Anderson Creek Road have. He advised that the homeowners were pro access and snowmobiling.

Recreation Director, Larry Laxson advised that he would be willing to meeting with the homeowners in Anderson Creek to see if an arrangement could be made for an additional 12 feet easement. Mr. Ed Priddy advised that they would be willing to discuss with the Recreation Director, Larry Laxson.

Chairman Hasbrouck closed the Public Hearing at 2:05 p.m. and brought the matter back for deliberations. The commissioners discussed the matter in detail. Chairman Hasbrouck made a motion to approve Ordinance 21-02 Snowmobile Ordinance. Commissioner Bingaman seconded the motion. No further discussion, all in favor. Motion passed to approve Ordinance 21-02 Snowmobile Ordinance.

IT Director, David Crawford presented on the request for website upgrade and provided a master services agreement with EvoGov. David informed the commissioners about what type of options were reviewed to update the existing Valley County Website. He provided information to the commissioners about the cost to go through EvoGov to \$8,500 with an ongoing maintenance cost of \$1,500 per year. He discussed additional features that the website would have available to Valley County and presented that individual departments would have the ability to modify their departments website. Commissioner Maupin made a motion to allow the upgrade to the Valley County Website and sign the Master Services agreement with EvoGov. Commissioner Bingaman seconded the motion. No further discussion, all in favor. Motion passed to allow the upgrade to the Valley County Website and sign the master services agreement with EvoGov.

Road Superintendent, Jeff McFadden presented an emergency application for Zena Creek Bridge. He advised that he had been searching for funding to replace the Zena Creek Bridge and advised that LHTAC has funding available due to the failing of the Zena Creek Bridge. Commissioner Bingaman made a motion to approve the application for funding through LHTAC for the Zena Creek Bridge replacement. Commissioner Maupin seconded the motion. No further discussion, all in favor. Motion passed to approve the application for funding through LHTAC for the Zena Creek Bridge replacement.

Road Superintendent, Jeff McFadden presented the credit application through Interstate Billing Service for Rush Enterprises. He advised that a plow truck lost a motor, and they need to replace a motor. Commissioner Maupin made a motion to approve the credit application. Commissioner Bingaman seconded the motion. No further discussion, all in favor. Motion passed to approve the credit application.

Assessor, June Fullmer presented on a cancellation of value# 18 for parcel RPM00000096979 and cancellation of value #19 for parcel RPM00000096981. She provided an overview of why there was a request for cancellation for value for the two parcels. Commissioner Maupin made a motion to approve the cancellation of value# 18 and cancellation of value# 19. Commissioner Bingaman seconded the motion. No further discussion, all in favor. Motion passed to approve the cancellation of value as presented for parcel RPM00000096979 and parcel RPM00000096981.

Commissioner Maupin made a motion to go into Executive Session per Idaho Code 74-206 1(b)-“to consider the evaluation dismissal or disciplining of, or to hear complaints or charges brought against, a public officer, employee, staff member or individual agent, or public school student.”-Personnel. Commissioner Bingaman seconded the motion. No further discussion, by roll call vote all commissioners voted “aye”. The commissioners went into Executive Session per Idaho Code 74-206 1(b)-Personnel at 3:27 p.m.

Chairman Hasbrouck brought the commissioners out of Executive Session per Idaho Code 74-206 1(b)-Personnel at 3:40 p.m.

The commissioners adjourned the meeting at 3:40 p.m.

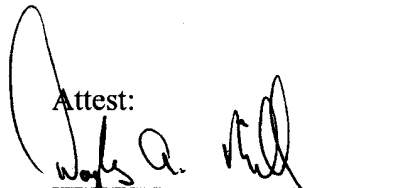
Attest:

Douglas Miller, Clerk



Chairman, Elting Hasbrouck

VALLEY COUNTY CANCELLATION OF TAXES

Cancellation #: 21-1

Parcel #: RPM00000091832

Tax Years: 2019

Bill #: 133942

Code Area: 003-0004

Name: Maureen Ferguson

Address: 802 Aspen Valley

City / State / Zip: McCall, ID 83638

Amount of Cancellation: Tax: \$0.00 Special Assessment: \$ ____ P & I Charge: \$ ~~368.58~~

184.29⁶⁵

Fee: \$ ~~64.28~~ Paid: \$ ____ Total: ~~\$432.86~~ \$216.43⁶⁵
32.14⁶⁵

Explanation: See attached application for cancellation of property taxes submitted by taxpayer.

Cancellation requested by: Maureen Ferguson

Cancelled By Board of Commissioners:

Date: 12/7/20

Approved: Disapproved:

\$216.43⁶⁵

Chairman's Signature: Elting H. Husbrink

Date Treasurer Notified: 12/7/20

Date Treasurer Cancelled: 12/8/20

Date Auditor Notified: 12/7/20

Date Assessor Notified: 12/7/20

APPLICATION FOR CANCELLATION OF PROPERTY TAXES
(HARDSHIP)

TO THE BOARD OF COUNTY COMMISSIONERS OF VALLEY COUNTY, IDAHO

Application is hereby made for cancellation of property tax due to a financial hardship, and in support thereof the following sworn statement is submitted, as required by Section 63-711, Idaho Code.

NAME OF PROPERTY OWNER: Maureen + Luke Ferguson DATE OF BIRTH: 07/20/1982
05/09/1977
ADDRESS 802 Aspen Alley CITY McCall STATE ID ZIP 83638

Status as of January 1, 20__ 65 or Older__ Veteran__ Blind__ Disabled__ Widow__

Number of persons living in household 4 Ages: 43, 38, 3, 8 months, __, __, __

Parcel Number RPM00000091832 Assessed Value \$399,144

Property Description (Real) 802 Aspen Alley

Property Description (Personal) _____

Have you applied for Circuit Breaker? Yes __ No X

Have you applied for Homeowners? Yes X No __

ASSETS:

Automobile: Make _____ Year _____ Value _____

OTHER PROPERTY OWNED:

Legal Description _____ Value _____

Have you disposed of property in the last 2 years? Yes __ No __ Comment: _____

Describe the circumstances that affect your ability to pay the property taxes on the above described property:

Please see Attached sheet

Late fee

Interest \$383.68 + \$64.28

(Attach additional pages, if necessary)

Amount of cancellation requested \$ _____ Tax year/years covered in request: 20 __, 20 __, 20 __.

Under the penalty of perjury, I certify to the best of my knowledge and belief the information that I have provided herein is true, correct, and complete:

DATE: 11/25/20 PHONE NO: 208-871-8753 SIGNATURE: [Signature]

Note: Financial statement subscribed and sworn to must be attached to this application.

To the Board of County Commissioners of Valley County

I am writing to you to request cancellation of interest of \$383.64 and late fee of \$ 64.28 accrued on my Valley county property taxes. On November 23rd I received my Valley County tax statement noting that I had been delinquent on my property taxes and had accrued these fees. I called the Tax Collector to inquire about this as I had not received a prior statement. In discussion with the secretary as well as Gabe Stayton this bill was mailed in June. We had change of address in May from a PO box to physical mailbox at our house and I called and changed this address with the Assessor's office on June 3rd, 2020. Reportedly our Tax statement was mailed shortly after. Unfortunately, we did not receive this despite mail being forwarded. The November 23rd tax statement was the first time that I became aware that I was unknowingly delinquent on my taxes. I attempted to remedy this issue with Mr. Stayton, but he was unable to assist me thus I am reaching out to you.

Though I understand legally this does not entitle me to cancellation of the interest and late fee, I am hopeful you will grant me this for reasons listed below.

1. I have paid in full both prior year and current year's taxes at this time.
2. I have never been delinquent on paying these taxes prior, nor any other bills.
3. Unfortunately, I have realized that we have not had a homeowner's exemption on our property for the last 5+ years in which we have been living at 802 Aspen Alley as our primary residence. Thus, I have been paying extra taxes to the county during this time.

Thank you so much for your consideration of this. I appreciate your time and commitment to our county. Please let me know if you have any questions.

Sincerely,

Mo and Luke Ferguson

VALLEY COUNTY TAX STATEMENT

GABE STAYTON
VALLEY COUNTY TAX COLLECTOR

P.O. Box 1350
 Cascade, ID 83611
 208-382-7110

Tax Year: 2020
 AIN: RPM0000091832
 PIN: RPM0000091832
 Code-Area: 003-0004

Bill Number: 111327
 Billing Date: 12/07/2020
 Balance good until: 12/07/2020
 Last Payment:

AUTO

FERGUSON MAUREEN F
 802 ASPEN VALLEY
 MCCALL ID 83638

Parcel Description: MCCALL ACREAGE TAX NO. 54 IN SE4 NE4 S9 T18N R3E
Location: 802 ASPEN ALLEY MCCALL Acres: 0.2300
Mortgage:
PAYMENTS RECEIVED WITH A DELINQUENCY WILL BE APPLIED TO THE OLDEST DELINQUENT TAX YEAR. TO AVOID LATE CHARGES, PAYMENTS MUST BE RECEIVED OR POSTMARKED BY THE DUE DATE.

Values	Amount	Exemptions and Credits	Amount	Exemptions and Credits	Amount
Land Value	77,998				
Improvement Value	321,146				
Total Taxable					399,144

Taxing District	Phone	Rate	Total	Spec. Assessments	Phone	Rate	Total
Valley County	208-382-7100	0.0014608800	\$583.10	Solid Waste		0	110.00
City of McCall	208-634-7142	0.0038096500	\$1,520.60				
School #421	208-634-2161	0.0012707650	\$507.22				
School #421 Bond	208-634-2161	0.0005322710	\$212.45				
School #421 Tort	208-634-2161	0.0000068590	\$2.74				
McCall Cemetery	208-634-2779	0	\$0.00				
McCall Rural Fire District	208-634-7070	0.0008726350	\$280.24				
Payette Lake Water/Sewer	208-634-4111	0.0001735220	\$69.26				
McCall Memorial Hospital	208-271-6678	0.0003064940	\$122.34				
Valley County EMS District	208-382-7100	0.0002237070	\$89.29				
				Urban Renewal			
Your bill includes Gov Little's one time tax reduction of:							
							City Savings 69.00

Bill Summary	Prior Year	Current	Delinquent	Interest	Late Fee	Fees	Paid	Total Due
	3,213.84	\$3,497.24	\$3,213.84	\$368.58	\$64.28	\$0.00	\$0.00	\$7,143.94

The mortgage companies have received a copy of the Valley County Tax File. If your mortgage company pays your taxes this notice is for information only. Credit and debit card payments are accepted through our website www.co.valley.id.us. All card transactions require your tax bill PIN, and are subject to a 2.50% convenience fee.

Make Check Payable to: VALLEY COUNTY TAX COLLECTOR **Keep top portion for your records**

FOR PROPER CREDIT RETURN THIS STUB WITH PAYMENT
PERSONAL CHECKS ARE SUBJECT TO BANK CLEARANCE

FERGUSON MAUREEN F
 802 ASPEN VALLEY
 MCCALL ID 83638

FERGUSON MAUREEN F
 802 ASPEN VALLEY
 MCCALL ID 83638

Bill Number: 2020 - 111327
 PIN: RPM0000091832
 AIN:
 VALLEY COUNTY

1ST HALF	\$5,395.32
FULL AMOUNT	

Bill Number: 2020 - 111327
 PIN: RPM0000091832
 AIN:
 VALLEY COUNTY

2ND HALF	\$1,748.62
----------	------------

\$7,143.94

December 21, 2020

June 21, 2021



VALLEY COUNTY CANCELLATION OF TAXES

Cancellation #: 21-2

Parcel #: RP00216015014A

Tax Years: 2020

Bill #: 104991

Code Area: 068-0000

Name: Long Valley Preservation Society

Address: PO Box 444

City / State / Zip: Donnelly, ID 83615

Amount of Cancellation: Tax: \$0.00 Special Assessment: \$ 330.00 P & I Charge: \$ 0.00

Fee: \$ 0.00 Paid: \$ Total: \$330.00

Explanation: They already pay Solid Waste on multiple properties.

Cancellation requested by: June Fullmer

Cancelled By Board of Commissioners:

Date: 12/7/20

Approved: Disapproved:

Chairman's Signature: *Etting D. Husbrowck*

Date Treasurer Notified: 12/7/20

Date Treasurer Cancelled: 12/8/20

Date Auditor Notified: 12/7/20

Date Assessor Notified: 12/7/20

VALLEY COUNTY TAX STATEMENT

GABE STAYTON
VALLEY COUNTY TAX COLLECTOR
 P.O. Box 1350
 Cascade, ID 83611
 208-382-7110

Tax Year: 2020
 AIN: RP00216015014A
 PIN: RP00216015014A
 Code-Area: 068-0000

Bill Number: 104991
 Billing Date: 11/30/2020
 Balance good until: 11/30/2020
 Last Payment:

AUTO

 LONG VALLEY PRESERVATION SOCIETY
 PO BOX 444
 DONNELLY ID 83615

Parcel Description: ROSEBERRY TOWNSITE LOTS 11 THRU 14 BLOCK 15 & PT. VACATED ALLEY
Location: 13131 FARM TO MARKET RD Acres: 0.2812 Mortgage:
PAYMENTS RECEIVED WITH A DELINQUENCY WILL BE APPLIED TO THE OLDEST DELINQUENT TAX YEAR. TO AVOID LATE CHARGES, PAYMENTS MUST BE RECEIVED OR POSTMARKED BY THE DUE DATE.

Values	Amount	Exemptions and Credits	Amount	Exemptions and Credits	Amount
Land Value	0				
Improvement Value	0				
Total Taxable					0

Taxing District	Phone	Rate	Total	Spec. Assessments	Phone	Rate	Total
Valley County	208-382-7100	0.0014608800	\$0.00	Rose Irrigation District		0	3.38
School #421	208-634-2161	0.0012707650	\$0.00	Solid Waste Commercial	REMOVE	0	330.00
School #421 Bond	208-634-2161	0.0005322710	\$0.00				
School #421 Tort	208-634-2161	0.0000068590	\$0.00				
Donnelly Rural Fire District	208-325-8619	0.0007789260	\$0.00				
McCall Memorial Hospital	208-271-6678	0.0003064940	\$0.00				
Valley County EMS District	208-382-7100	0.0002237070	\$0.00				
Donnelly Public Library	208-325-8237	0.0000487630	\$0.00				
				Urban Renewal	Phone	Rate	Total

Bill Summary	Prior Year	Current	Delinquent	Interest	Late Fee	Fees	Paid	Total Due
	333.38	\$333.38	\$0.00	\$0.00	\$0.00	\$0.00	\$0.00	\$333.38

The mortgage companies have received a copy of the Valley County Tax File. If your mortgage company pays your taxes this notice is for information only. Credit and debit card payments are accepted through our website www.co.valley.id.us. All card transactions require your tax bill PIN, and are subject to a 2.50% convenience fee.

Make Check Payable to: VALLEY COUNTY TAX COLLECTOR **Keep top portion for your records**

FOR PROPER CREDIT RETURN THIS STUB WITH PAYMENT PERSONAL CHECKS ARE SUBJECT TO BANK CLEARANCE LONG VALLEY PRESERVATION SOCIETY PO BOX 444 DONNELLY ID 83615	FOR PROPER CREDIT RETURN THIS STUB WITH PAYMENT PERSONAL CHECKS ARE SUBJECT TO BANK CLEARANCE LONG VALLEY PRESERVATION SOCIETY PO BOX 444 DONNELLY ID 83615
---	---

Bill Number: 2020 - 104991
 PIN: RP00216015014A
 AIN:
 VALLEY COUNTY

1ST HALF
\$166.69
FULL AMOUNT
\$333.38

Bill Number: 2020 - 104991
 PIN: RP00216015014A
 AIN:
 VALLEY COUNTY

2ND HALF
\$166.69

December 21, 2020

June 21, 2021



ADMINISTRATIVE INFORMATION
 PARCEL NUMBER
 RP00216015014A
 Parent Parcel Number
 RP00216015014A
 Property Address
 13131 FARM TO MARKET RD
 Neighborhood
 700000 Exempt Properties
 Property Class
 681 681 Exempt Prop State Statute
TAXING DISTRICT INFORMATION
 Jurisdiction 43
 Area 001
 District 068-00

OWNERSHIP
 LONG VALLEY PRESERVATION SOCIETY
 MC ADAMS FAYE
 PO BOX 444
 DONNELLY, ID 83615
 ROSEBERRY TOWNSITE LOTS 11 THRU 14 BLOCK 15 & PT.
 VACATED ALLEY

TRANSFER OF OWNERSHIP
 Date
 08/23/1962 LONG VALLEY PRESERVATION SOCIETY 50
 Bk/Pg: 35, 86

EXEMPT

VALUATION RECORD

Assessment Year	01/01/2015	01/01/2015	01/01/2016	01/01/2017	01/01/2018	01/01/2019	01/01/2020
Reason for Change	02- Assessme	07- Assr Cor	02- Assessme	01- Revaluat	01- Revaluat	01- Revaluat	01- Revaluat
VALUATION	L 25104	0	0	0	0	0	0
Market Value	B 22605	0	0	0	0	0	0
	T 47709	0	0	0	0	0	0

Site Description

Legal Acres:
 0.2812

LAND DATA AND CALCULATIONS

Land Type	Rating Soil ID -or- Actual Frontage	Measured Acreage -or- Effective Frontage	Table Effective Depth	Prod. Factor -or- Depth Factor -or- Square Feet	Base Rate	Adjusted Rate	Extended Value	Influence Factor	Value
1 Market Value		0.2812		1.00	0.00	0.00	0		SV 0

0216: ROSEBERRY, TOWNSITE OF (16N R3
 BE15: Board of Equalization for 2015
 Cancel value per BOE
 CU15: Change of use for 2015
 Cat 81 to Cat 15 & 32
 MISC: Exempt Property per I.C. 63-602c
 MUSEUM AND CHURCH
 RY19: Review Year for 2019
 VC15: Value Change for 2015
 Removal of exempt status per 63-602

FARMLAND COMPUTATIONS

Parcel Acreage
 81 Legal Drain NV [-]
 82 Public Roads NV [-]
 83 UT Towers NV [-]
 9 Homesite(s) [-]
 91/92 Excess Acreage [-]
 TOTAL ACRES FARMLAND
 TRUE TAX VALUE

0.2812 Measured Acreage
 Average True Tax Value/Acre
 TRUE TAX VALUE FARMLAND
 Classified Land Total
 Homesite(s) Value (+)
 Excess Acreage Value (+)

Supplemental Cards

TRUE TAX VALUE

Supplemental Cards
 TOTAL LAND VALUE

IMPROVEMENT DATA

PHYSICAL CHARACTERISTICS

Wd Dk 168
01 school
RFX
Wd Dk 110

02 church
EFP 84

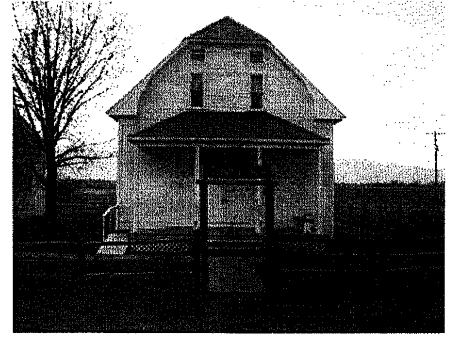

(LCM: 100.00)

SPECIAL FEATURES

SUMMARY OF IMPROVEMENTS

Description	Value	ID	Use	Sty Hgt	Const Type	Grade	Year Const	Eff Year	Cond	Base Rate	Feat-ures	Adj Rate	Size or Area	Computed Value	Phys Depr	Obsol Depr	Market Adj	% Comp	Value
01 :ATTIC FINISHLO	0	01	POLEBLDG	9.00		Avg	1920	1950	AV	0.00	Y	0.00	27x 56	0	0	SV	0	100	0
02 :FINISHLO	0	02	POLEBLDG	10.00		Avg	1920	1950	AV	0.00	Y	0.00	24x 40	0	0	SV	0	100	0

Data Collector/Date
DW 07/23/2018

Appraiser/Date
DW 03/13/2019

Neighborhood
Neigh 700000 AV

Supplemental Cards
TOTAL IMPROVEMENT VALUE

VALLEY COUNTY CANCELLATION OF TAXES

Cancellation #: 21-3

Parcel #: RP00216003005A

Tax Years: 2020

Bill #: 105613

Code Area: 068-0000

Name: Long Valley Preservation Society

Address: PO Box 444

City / State / Zip: Donnelly, ID 83615

Amount of Cancellation: Tax: \$0.00 Special Assessment: \$ 330.00 ^{110.00 G} P & I Charge: \$ 0.00

Fee: \$ 0.00 Paid: \$ Total: \$ 330.00 ^{110.00 G}

Explanation: They already pay Solid Waste on multiple properties.

Cancellation requested by: June Fullmer

Cancelled By Board of Commissioners:

Date: 12/7/20

Approved: Disapproved: ^{110.00 G}

Chairman's Signature: Elting S. Hasbrouck

Date Treasurer Notified: 12/7/20

Date Treasurer Cancelled: 12/8/20

Date Auditor Notified: 12/7/20

Date Assessor Notified: 12/7/20

VALLEY COUNTY TAX STATEMENT

GABE STAYTON
VALLEY COUNTY TAX COLLECTOR

P.O. Box 1350
 Cascade, ID 83611
 208-382-7110

Tax Year: 2020
 AIN: RP00216003005A
 PIN: RP00216003005A
 Code-Area: 068-0000

Bill Number: 105613
 Billing Date: 11/30/2020
 Balance good until: 11/30/2020
 Last Payment:

AUTO

 LONG VALLEY PRESERVATION SOCIETY
 PO BOX 444
 DONNELLY ID 83615

Parcel Description: ROSEBERRY TOWNSITE LOTS 5 THRU 10; LOTS 19 THRU 24 AND PT. VACATED ALLEY; PT. VACATED CLARK AND EAST STREETS
Location: 13130 FARM TO MARKET RD Acres: 1.1190 Mortgage:
PAYMENTS RECEIVED WITH A DELINQUENCY WILL BE APPLIED TO THE OLDEST DELINQUENT TAX YEAR. TO AVOID LATE CHARGES, PAYMENTS MUST BE RECEIVED OR POSTMARKED BY THE DUE DATE.

Values	Amount	Exemptions and Credits	Amount	Exemptions and Credits	Amount
Land Value	0				
Improvement Value	0				
Total Taxable					0

Taxing District	Phone	Rate	Total	Spec. Assessments	Phone	Rate	Total
Valley County	208-382-7100	0.0014608800	\$0.00	Solid Waste		0	110.00
School #421	208-634-2161	0.0012707650	\$0.00				
School #421 Bond	208-634-2161	0.0005322710	\$0.00				
School #421 Tort	208-634-2161	0.0000068590	\$0.00				
Donnelly Rural Fire District	208-325-8619	0.0007789260	\$0.00				
McCall Memorial Hospital	208-271-6678	0.0003064940	\$0.00				
Valley County EMS District	208-382-7100	0.0002237070	\$0.00				
Donnelly Public Library	208-325-8237	0.0000487630	\$0.00				
				Urban Renewal	Phone	Rate	Total

Bill Summary	Prior Year	Current	Delinquent	Interest	Late Fee	Fees	Paid	Total Due
	110.00	\$110.00	\$0.00	\$0.00	\$0.00	\$0.00	\$0.00	\$110.00

The mortgage companies have received a copy of the Valley County Tax File. If your mortgage company pays your taxes this notice is for information only. Credit and debit card payments are accepted through our website www.co.valley.id.us. All card transactions require your tax bill PIN, and are subject to a 2.50% convenience fee.

Make Check Payable to: VALLEY COUNTY TAX COLLECTOR **Keep top portion for your records**

FOR PROPER CREDIT RETURN THIS STUB WITH PAYMENT
PERSONAL CHECKS ARE SUBJECT TO BANK CLEARANCE
FOR PROPER CREDIT RETURN THIS STUB WITH PAYMENT
PERSONAL CHECKS ARE SUBJECT TO BANK CLEARANCE

LONG VALLEY PRESERVATION SOCIETY
 PO BOX 444
 DONNELLY ID 83615

LONG VALLEY PRESERVATION SOCIETY
 PO BOX 444
 DONNELLY ID 83615

Bill Number: 2020 - 105613
 PIN: RP00216003005A
 AIN:

1ST HALF

\$55.00

FULL AMOUNT

Bill Number: 2020 - 105613
 PIN: RP00216003005A
 AIN:

2ND HALF

\$55.00

VALLEY COUNTY

VALLEY COUNTY

\$110.00

December 21, 2020

June 21, 2021



ADMINISTRATIVE INFORMATION
 PARCEL NUMBER
 RP00216003005A
 Parent Parcel Number
 RP00216003005A
 Property Address
 13130 FARM TO MARKET RD
 Neighborhood
 70000 Exempt Properties
 Property Class
 681 681 Exempt Prop State Statute
TAXING DISTRICT INFORMATION
 Jurisdiction 43
 Area 001
 District 068-00

OWNERSHIP
 LONG VALLEY PRESERVATION SOCIETY
 PO BOX 444
 DONNELLY, ID 83615
 ROSEBERRY TOWNSITE LOTS 5 THRU 10; LOTS 19 THRU 24 AND
 PT. VACATED ALLEY; PT.
 VACATED CLARK AND EAST STREETS

TRANSFER OF OWNERSHIP
 Date

EXEMPT

VALUATION RECORD

Assessment Year	01/01/2015	01/01/2015	01/01/2016	01/01/2017	01/01/2018	01/01/2019	01/01/2020
Reason for Change	02- Assessme	07- Assr Cor	02- Assessme	01- Revaluat	01- Revaluat	01- Revaluat	01- Revaluat
VALUATION	L 29210	0	0	0	0	0	0
Market Value	B 18198	0	0	0	0	0	0
	T 47408	0	0	0	0	0	0

Site Description

Legal Acres:
 1.1190

LAND DATA AND CALCULATIONS

Land Type	Rating Soil ID -or- Actual Frontage	Measured Acreage -or- Effective Frontage	Table Effective Depth	Prod. Factor -or- Depth Factor -or- Square Feet	Base Rate	Adjusted Rate	Extended Value	Influence Factor	Value
1 Market Value		1.0000		1.00	0.00	0.00	0		SV 0
2 Market Value		0.1190		1.00	0.00	0.00	0		SV 0

0216: ROSEBERRY, TOWNSITE OF (16N R3
 BE15: Board of Equalization for 2015
 Cancel value per BOE
 CU15: Change of use for 2015
 Cat 81 to Cat 15 & 32
 MISC: Exempt Property per I.C. 63-602c
 RED BARN & MISC BLDGS, and Johnson House on record 2
 RY19: Review Year for 2019
 VC15: Value Change for 2015
 Exempt status removed did
 not provide proper paper work
 by deadline. 63-602
 VC17: Value change for 2017
 Voided LR00216003015A and moved the Johnson House to
 RP00216003005A for 2017 per JP

FARMLAND COMPUTATIONS
 Parcel Acreage
 81 Legal Drain NV [-]
 82 Public Roads NV [-]
 83 UT Towers NV [-]
 9 Homesite(s) [-]
 91/92 Excess Acreage [-]
TOTAL ACRES FARMLAND
 TRUE TAX VALUE

1.1190 Measured Acreage
 Average True Tax Value/Acre
TRUE TAX VALUE FARMLAND
 Classified Land Total
 Homesite(s) Value (+)
 Excess Acreage Value (+)

Supplemental Cards
 TRUE TAX VALUE

Supplemental Cards
TOTAL LAND VALUE

IMPROVEMENT DATA

PHYSICAL CHARACTERISTICS

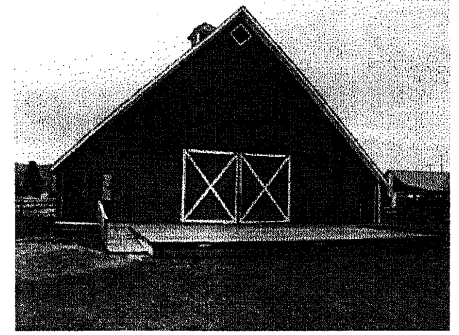
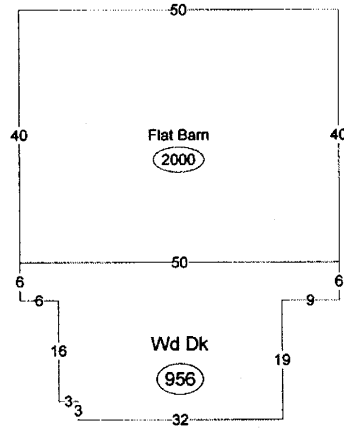

(LCM: 100.00)

SPECIAL FEATURES

SUMMARY OF IMPROVEMENTS

Description	Value	ID	Use	Stry Hgt	Const Type	Year Const	Eff Year	Base Rate	Feat-ures	Adj Rate	Size or Area	Computed Value	Phys Depr	Obsol Depr	Market Adj	* Comp	Value	
01 FLATBARN				9.00	1	Fair	1920 1950	AV	0.00	N	0.00	40x 50	0	0	SV	0	100	0
02 WDDK				0.00		Avg	2000 2000	AV	0.00	N	0.00	956	0	0	SV	0	0	0

Date Collector/Date

DW 07/23/2018

Appraiser/Date

DW 03/12/2019

Neighborhood

Neigh 700000 AV

Supplemental Cards

TOTAL IMPROVEMENT VALUE

IMPROVEMENT DATA

JOHNSON CABIN

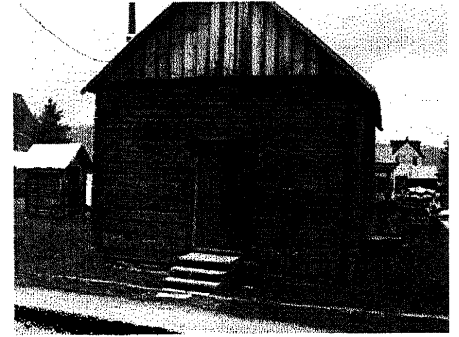
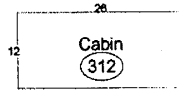

PHYSICAL CHARACTERISTICS

(LCM: 100.00)

SPECIAL FEATURES

SUMMARY OF IMPROVEMENTS

Description	Value	ID	Use	Sty Hgt	Const Type	Grade	Year Const	Eff Year	Cond	Base Rate	Feat-ures	Adj Rate	Size or Area	Computed Value	PhysObsol	Market Depr	% Adj	Comp	Value	
01 :ATTIC	0	01	CABIN	8.00	0	Fair	1920	1960	F	0.00	Y	0.00	12x 26	0	0	SV	0	100	0	
NP	0																			
WDSTOVE	0																			

Data Collector/Date
DW 07/23/2018

Appraiser/Date
DW 03/12/2019

Neighborhood
Neigh 700000 AV

Supplemental Cards
TOTAL IMPROVEMENT VALUE

VALLEY COUNTY CANCELLATION OF TAXES

Cancellation #: 21-4

Parcel #: RP002480000250

Tax Years: 2020

Bill #: 105233

Code Area: 039-0000

Name: Eric Hodge

Address: 3621 N Shamrock Ave

City / State / Zip: Boise, ID 83713

Amount of Cancellation: Tax: \$0.00 Special Assessment: \$ 2972.66 P & I Charge: \$ 0.00

Fee: \$ 0.00 Paid: \$ Total: \$2972.66

Explanation: The fees were paid to Northlake and were not taken off the list to be certified.

Cancellation requested by: Gabe Stayton

Cancelled By Board of Commissioners:

Date: 12/7/20

Approved: Disapproved:

Chairman's Signature: Etting A. Hasbrouck

Date Treasurer Notified: 12/7/20

Date Treasurer Cancelled: 12/8/20

Date Auditor Notified: 12/7/20

Date Assessor Notified: 12/7/20

VALLEY COUNTY TAX STATEMENT

GABE STAYTON
VALLEY COUNTY TAX COLLECTOR

P.O. Box 1350
 Cascade, ID 83611
 208-382-7110

Tax Year: 2020
 AIN: RP002480000250
 PIN: 039-0000
 Code-Area: 039-0000

Bill Number: 105233
 Billing Date: 11/24/2020
 Balance good until: 11/24/2020
 Last Payment: 08/07/2020

AUTO

 HODGE ERIC
 3621 N SHAMROCK AVE
 BOISE ID 83713

Parcel Description: SMILING JULIE SUBDIVISION LOT 25
Location: 323 JULIE LN Acres: 0.3166
Mortgage:
PAYMENTS RECEIVED WITH A DELINQUENCY WILL BE APPLIED TO THE OLDEST DELINQUENT TAX YEAR. TO AVOID LATE CHARGES, PAYMENTS MUST BE RECEIVED OR POSTMARKED BY THE DUE DATE.

Values	Amount	Exemptions and Credits	Amount	Exemptions and Credits	Amount
Land Value	23,519				
Improvement Value	0				
Total Taxable					23,519

Taxing District	Phone	Rate	Total	Spec. Assessments	Phone	Rate	Total
Valley County	208-382-7100	0.0014608800	\$34.36	Forest Practices Act		0	3.24
School #421	208-634-2161	0.0012707650	\$29.89	Forest Assessment		0	15.00
School #421 Bond	208-634-2161	0.0005322710	\$12.52	North Lake S/W Bill		0	2,972.66
School #421 Tort	208-634-2161	0.0000068590	\$0.16				
Valley Center Cemetery	208-315-4521	0.0000328430	\$0.77				
Donnelly Rural Fire District	208-325-8619	0.0007789260	\$18.32				
North Lake Rec Sewer/Water	208-325-8958	0.0002771860	\$6.52				
McCall Memorial Hospital	208-271-6678	0.0003064940	\$7.21				
Valley County EMS District	208-382-7100	0.0002237070	\$5.26				
Edwards Mosquito Abatement	208-315-2101	0.0002374670	\$5.58				
Donnelly Public Library	208-325-8237	0.0000487630	\$1.15				
				Urban Renewal	Phone	Rate	Total

Bill Summary	Prior Year	Current	Delinquent	Interest	Late Fee	Fees	Paid	Total Due
	3,107.66	\$3,112.64	\$0.00	\$0.00	\$0.00	\$0.00	\$7.87	\$3,104.77

The mortgage companies have received a copy of the Valley County Tax File. If your mortgage company pays your taxes this notice is for information only. Credit and debit card payments are accepted through our website www.co.valley.id.us. All card transactions require your tax bill PIN, and are subject to a 2.50% convenience fee.

Make Check Payable to: VALLEY COUNTY TAX COLLECTOR **Keep top portion for your records**

FOR PROPER CREDIT RETURN THIS STUB WITH PAYMENT PERSONAL CHECKS ARE SUBJECT TO BANK CLEARANCE	FOR PROPER CREDIT RETURN THIS STUB WITH PAYMENT PERSONAL CHECKS ARE SUBJECT TO BANK CLEARANCE
--	--

HODGE ERIC
 3621 N SHAMROCK AVE
 BOISE ID 83713

HODGE ERIC
 3621 N SHAMROCK AVE
 BOISE ID 83713

Bill Number: 2020 - 105233
 PIN: RP002480000250
 AIN:

1ST HALF
\$1,548.45
FULL AMOUNT

Bill Number: 2020 - 105233
 PIN: RP002480000250
 AIN:

2ND HALF
\$1,556.32

VALLEY COUNTY

VALLEY COUNTY

\$3,104.77

December 21, 2020

June 21, 2021



VALLEY COUNTY CANCELLATION OF TAXES

Cancellation #: 21-5

Parcel #: RP001140000210

Tax Years: 2020

Bill #: 103781

Code Area: 039-0000

Name: Brian Coriell

Address: 3765 S TICONDEROGA

City / State / Zip: Boise, ID 83706

Amount of Cancellation: Tax: \$0.00 Special Assessment: \$ 129.00 P & I Charge: \$ 0.00

Fee: \$ 0.00 Paid: \$ Total: \$129.00

Explanation: The fees were paid to Northlake and were not taken off the list to be certified.

Cancellation requested by: Gabe Stayton

Cancelled By Board of Commissioners:

Date: 12/7/20

Approved: Disapproved:

Chairman's Signature: Elting D. Hasbrouck

Date Treasurer Notified: 12/7/20

Date Treasurer Cancelled: 12/8/20

Date Auditor Notified: 12/7/20

Date Assessor Notified: 12/7/20

VALLEY COUNTY CANCELLATION OF TAXES

Cancellation #: 21-6

Parcel #: RP00135000001A

Tax Years: 2020

Bill #: 700375

Code Area: 039-0000

Name: JASON MCCARLEY

Address: PO BOX 269

City / State / Zip: MCCALL, ID 83638

Amount of Cancellation: Tax: \$0.00 Special Assessment: \$ 1099.23 P & I Charge: \$ 0.00

Fee: \$ 0.00 Paid: \$ Total: \$1099.23

Explanation: The fees were paid to Northlake and were not taken off the list to be certified.

Cancellation requested by: Gabe Stayton

Cancelled By Board of Commissioners:

Date: 12/7/20

Approved: Disapproved:

Chairman's Signature: *Etting B. Hasbrouck*

Date Treasurer Notified: 12/7/20

Date Treasurer Cancelled: 12/8/20

Date Auditor Notified: 12/7/20

Date Assessor Notified: 12/7/20

HL6

VALLEY COUNTY TAX STATEMENT

GABE STAYTON
VALLEY COUNTY TAX COLLECTOR

P.O. Box 1350
Cascade, ID 83611
208-382-7110

Tax Year: 2020
AIN: RP00135000001A
PIN:
Code-Area: 039-0000

Bill Number: 700375
Billing Date: 12/01/2020
Balance good until: 12/01/2020
Last Payment:

Parcel Description: LAKE CASCADE RANCH SUBDIVISION LOT 1 1983
STONERIDGE 28X56 M.H. ON MH ROLL SER#IDFL2A/B,D28043424

Location: 1749 W ROSEBERRY RD
Acres: 0.4590
Mortgage:

PAYMENTS RECEIVED WITH A DELINQUENCY WILL BE APPLIED TO THE OLDEST DELINQUENT TAX YEAR. TO AVOID LATE CHARGES, PAYMENTS MUST BE RECEIVED OR POSTMARKED BY THE DUE DATE.

AUTO
MC CARLEY JASON
PO BOX 269
MCCALL ID 83638

Values	Amount	Exemptions and Credits	Amount	Exemptions and Credits	Amount
Land Value	55,006	Homeowners Exemption	32,948		
Improvement Value	10,889				
				Total Taxable	32,947

Taxing District	Phone	Rate	Total	Spec. Assessments	Phone	Rate	Total
Valley County	208-382-7100	0.0014608800	\$48.14	Forest Practices Act		0	3.24
School #421	208-634-2161	0.0012707650	\$41.87	Forest Assessment		0	55.00
School #421 Bond	208-634-2161	0.0005322710	\$17.54	North Lake SAW Bill		0	1,099.23
School #421 Tort	208-634-2161	0.0000068590	\$0.23	Solid Waste		0	110.00
Valley Center Cemetery	208-315-4521	0.0000328430	\$1.08				
Donnelly Rural Fire District	208-325-8619	0.0007789260	\$25.86				
North Lake Rec Sewer/Water	208-325-8958	0.0002771860	\$9.13				
McCall Memorial Hospital	208-271-6678	0.0003064940	\$10.10				
Valley County EMS District	208-382-7100	0.0002237070	\$7.37				
Edwards Mosquito Abatement	208-315-2101	0.0002374670	\$7.82				
Donnelly Public Library	208-325-8237	0.0000487630	\$1.61				
				Urban Renewal	Phone	Rate	Total

Bill Summary	Prior Year	Current	Delinquent	Interest	Late Fee	Fees	Paid	Total Due
	1,384.76	\$1,438.02	\$0.00	\$0.00	\$0.00	\$0.00	\$0.00	\$1,438.02

The mortgage companies have received a copy of the Valley County Tax File. If your mortgage company pays your taxes this notice is for information only. Credit and debit card payments are accepted through our website www.co.valley.id.us. All card transactions require your tax bill PIN, and are subject to a 2.50% convenience fee.

Make Check Payable to: VALLEY COUNTY TAX COLLECTOR

Keep top portion for your records

**FOR PROPER CREDIT RETURN THIS STUB WITH PAYMENT
PERSONAL CHECKS ARE SUBJECT TO BANK CLEARANCE**

**FOR PROPER CREDIT RETURN THIS STUB WITH PAYMENT
PERSONAL CHECKS ARE SUBJECT TO BANK CLEARANCE**

MC CARLEY JASON
PO BOX 269
MCCALL ID 83638

MC CARLEY JASON
PO BOX 269
MCCALL ID 83638

Bill Number: 2020 - 700375
PIN: RP00135000001A
AIN:
VALLEY COUNTY

1ST HALF
\$719.01
FULL AMOUNT

Bill Number: 2020 - 700375
PIN: RP00135000001A
AIN:
VALLEY COUNTY

2ND HALF
\$719.01

\$1,438.02

December 21, 2020

June 21, 2021



VALLEY COUNTY CANCELLATION OF TAXES

Cancellation #: 21-7

Parcel #: RP001350000120

Tax Years: 2020

Bill #: 103399

Code Area: 039-0000

Name: STEVEN STGERMAIN

Address: 5915 S BERNARD

City / State / Zip: SPOKANE, WA 99224

Amount of Cancellation: Tax: \$0.00 Special Assessment: \$ 184.05 P & I Charge: \$ 0.00

Fee: \$ 0.00 Paid: \$ Total: \$184.05

Explanation: The fees were paid to Northlake and were not taken off the list to be certified.

Cancellation requested by: Gabe Stayton

Cancelled By Board of Commissioners:

Date: 12/17/20

Approved: Disapproved:

Chairman's Signature: Elting H. Husbrouck

Date Treasurer Notified: 12/7/20

Date Treasurer Cancelled: 12/8/20

Date Auditor Notified: 12/7/20

Date Assessor Notified: 12/7/20

VALLEY COUNTY TAX STATEMENT

GABE STAYTON
VALLEY COUNTY TAX COLLECTOR

P.O. Box 1350
 Cascade, ID 83611
 208-382-7110

Tax Year: 2020
 AIN: RP001350000120
 PIN:
 Code-Area: 039-0000

Bill Number: 103399
 Billing Date: 12/01/2020
 Balance good until: 12/01/2020
 Last Payment:

#7

Parcel Description: LAKE CASCADE RANCH SUBDIVISION LOT 12
Location: 148 CASEY LN Acres: 0.4970
Mortgage:
PAYMENTS RECEIVED WITH A DELINQUENCY WILL BE APPLIED TO THE OLDEST DELINQUENT TAX YEAR. TO AVOID LATE CHARGES, PAYMENTS MUST BE RECEIVED OR POSTMARKED BY THE DUE DATE.

AUTO

 ST GERMAIN STEVEN
 5915 S BERNARD
 SPOKANE WA 99224

Values	Amount	Exemptions and Credits	Amount	Exemptions and Credits	Amount
Land Value	57,056				
Improvement Value	0				
Total Taxable					57,056

Taxing District	Phone	Rate	Total	Spec. Assessments	Phone	Rate	Total
Valley County	208-382-7100	0.0014608800	\$83.36	Forest Practices Act		0	3.24
School #421	208-634-2161	0.0012707650	\$72.50	Forest Assessment		0	15.00
School #421 Bond	208-634-2161	0.0005322710	\$30.37	North Lake SAW Bill		0	184.05
School #421 Tort	208-634-2161	0.0000068590	\$0.39				
Valley Center Cemetery	208-315-4521	0.0000328430	\$1.87				
Donnelly Rural Fire District	208-325-8619	0.0007789260	\$44.44				
North Lake Rec Sewer/Water	208-325-8958	0.0002771860	\$15.82				
McCall Memorial Hospital	208-271-8678	0.0003064940	\$17.49				
Valley County EMS District	208-382-7100	0.0002237070	\$12.78				
Edwards Mosquito Abatement	208-315-2101	0.0002374670	\$13.55				
Donnelly Public Library	206-325-8237	0.0000487630	\$2.78				
				Urban Renewal	Phone	Rate	Total

Bill Summary	Prior Year	Current	Delinquent	Interest	Late Fee	Fees	Paid	Total Due
	376.72	\$497.62	\$678.92	\$127.48	\$13.59	\$0.00	\$0.00	\$1,317.61

The mortgage companies have received a copy of the Valley County Tax File. If your mortgage company pays your taxes this notice is for information only. Credit and debit card payments are accepted through our website www.co.valley.id.us. All card transactions require your tax bill PIN, and are subject to a 2.50% convenience fee.

Make Check Payable to: VALLEY COUNTY TAX COLLECTOR

Keep top portion for your records

**FOR PROPER CREDIT RETURN THIS STUB WITH PAYMENT
 PERSONAL CHECKS ARE SUBJECT TO BANK CLEARANCE**

**FOR PROPER CREDIT RETURN THIS STUB WITH PAYMENT
 PERSONAL CHECKS ARE SUBJECT TO BANK CLEARANCE**

ST GERMAIN STEVEN
 5915 S BERNARD
 SPOKANE WA 99224

ST GERMAIN STEVEN
 5915 S BERNARD
 SPOKANE WA 99224

Bill Number: 2020 - 103399
 PIN: RP001350000120
 AIN:
 VALLEY COUNTY

1ST HALF
\$1,068.80
FULL AMOUNT

Bill Number: 2020 - 103399
 PIN: RP001350000120
 AIN:
 VALLEY COUNTY

2ND HALF
\$248.81

\$1,317.61

December 21, 2020

June 21, 2021



VALLEY COUNTY CANCELLATION OF TAXES

Cancellation #: 21-8

Parcel #: RP001360000030

Tax Years: 2020

Bill #: 103750

Code Area: 039-0000

Name: AARON JONES

Address: 1418 CRESTVIEW DR

City / State / Zip: NEWBERG, OR 97132

Amount of Cancellation: Tax: \$0.00 Special Assessment: \$ 388.25 P & I Charge: \$ 0.00

Fee: \$ 0.00 Paid: \$ Total: \$388.25

Explanation: The fees were paid to Northlake and were not taken off the list to be certified.

Cancellation requested by: Gabe Stayton

Cancelled By Board of Commissioners:

Date: 12/7/20

Approved: Disapproved:

Chairman's Signature: Elting D. Hasbrouck

Date Treasurer Notified: 12/7/20

Date Treasurer Cancelled: 12/8/20

Date Auditor Notified: 12/7/20

Date Assessor Notified: 12/7/20

VALLEY COUNTY TAX STATEMENT

H2

GABE STAYTON
VALLEY COUNTY TAX COLLECTOR
 P.O. Box 1350
 Cascade, ID 83611
 208-382-7110

Tax Year: 2020
 AIN: RP001360000030
 PIN:
 Code-Area: 039-0000

Bill Number: 103750
 Billing Date: 12/01/2020
 Balance good until: 12/01/2020
 Last Payment: 11/06/2020

Parcel Description: LAZY SEVEN SUBDIVISION LOT 3
Location: 12836 HEREFORD RD Acres: 0.6239
Mortgage:
PAYMENTS RECEIVED WITH A DELINQUENCY WILL BE APPLIED TO THE OLDEST DELINQUENT TAX YEAR. TO AVOID LATE CHARGES, PAYMENTS MUST BE RECEIVED OR POSTMARKED BY THE DUE DATE.

AUTO

 JONES AARON
 1418 CRESTVIEW DR
 NEWBERG OR 97132

Values	Amount	Exemptions and Credits	Amount	Exemptions and Credits	Amount
Land Value	60,464				
Improvement Value	160,507				
Total Taxable					220,971

Taxing District	Phone	Rate	Total	Spec. Assessments	Phone	Rate	Total
Valley County	208-382-7100	0.0014808600	\$322.81	Forest Practices Act		0	3.24
School #421	208-634-2161	0.0012707650	\$280.80	Forest Assessment		0	55.00
School #421 Bond	208-634-2161	0.0005322710	\$117.62	North Lake SAW Bill		0	388.25
School #421 Tort	208-634-2161	0.0000068590	\$1.52	Solid Waste		0	110.00
Valley Center Cemetery	208-315-4521	0.0000328430	\$7.26				
Donnelly Rural Fire District	208-325-8619	0.0007789260	\$172.12				
North Lake Rec Sewer/Water	208-325-8958	0.0002771860	\$61.25				
McCall Memorial Hospital	208-271-8678	0.0003084940	\$67.73				
Valley County EMS District	208-382-7100	0.0002237070	\$49.43				
Edwards Mosquito Abatement	208-315-2101	0.0002374670	\$52.47				
Donnelly Public Library	208-325-8237	0.0000487630	\$10.78				
				Urban Renewal	Phone	Rate	Total

Bill Summary	Prior Year	Current	Delinquent	Interest	Late Fee	Fees	Paid	Total Due
	1,166.28	\$1,700.28	\$0.00	\$0.00	\$0.00	\$0.00	\$490.00	\$1,210.28

The mortgage companies have received a copy of the Valley County Tax File. If your mortgage company pays your taxes this notice is for information only. Credit and debit card payments are accepted through our website www.co.valley.id.us. All card transactions require your tax bill PIN, and are subject to a 2.50% convenience fee.

Make Check Payable to: VALLEY COUNTY TAX COLLECTOR

Keep top portion for your records

**FOR PROPER CREDIT RETURN THIS STUB WITH PAYMENT
 PERSONAL CHECKS ARE SUBJECT TO BANK CLEARANCE**

**FOR PROPER CREDIT RETURN THIS STUB WITH PAYMENT
 PERSONAL CHECKS ARE SUBJECT TO BANK CLEARANCE**

JONES AARON
 1418 CRESTVIEW DR
 NEWBERG OR 97132

JONES AARON
 1418 CRESTVIEW DR
 NEWBERG OR 97132

Bill Number: 2020 - 103750
 PIN: RP001360000030
 AIN:
 VALLEY COUNTY

1ST HALF
\$360.14
FULL AMOUNT

Bill Number: 2020 - 103750
 PIN: RP001360000030
 AIN:
 VALLEY COUNTY

2ND HALF
\$850.14

\$1,210.28

December 21, 2020

June 21, 2021



VALLEY COUNTY CANCELLATION OF TAXES

Cancellation #: 21-9

Parcel #: RP00180003002A

Tax Years: 2020

Bill #: 115258

Code Area: 039-0000

Name: WENDY TIPPETTS

Address: 595 S 14TH ST

City / State / Zip: BOISE, ID 83702

Amount of Cancellation: Tax: \$0.00 Special Assessment: \$ 427.49 P & I Charge: \$ 0.00

Fee: \$ 0.00 Paid: \$ Total: \$427.49

Explanation: The fees were paid to Northlake and were not taken off the list to be certified.

Cancellation requested by: Gabe Stayton

Cancelled By Board of Commissioners:

Date: 12/7/20

Approved: Disapproved:

Chairman's Signature: Elting A. Hasbrouck

Date Treasurer Notified: 12/7/20

Date Treasurer Cancelled: 12/8/20

Date Auditor Notified: 12/7/20

Date Assessor Notified: 12/7/20

VALLEY COUNTY TAX STATEMENT

115258

GABE STAYTON
VALLEY COUNTY TAX COLLECTOR

P.O. Box 1350
 Cascade, ID 83611
 208-382-7110

Tax Year: 2020
 AIN: RP00180003002A
 PIN:
 Code-Area: 039-0000

Bill Number: 115258
 Billing Date: 12/01/2020
 Balance good until: 12/01/2020
 Last Payment:

AUTO

 TIPPETTS WENDY
 595 S 14TH ST
 BOISE ID 83702

Parcel Description: MCLEOD & EDWARDS WAGON WHEEL SUBDIVISION NO. 7 LOT 2 BLOCK 3
Location: 208 JACKS LN Acres: 0.9122 Mortgage:
PAYMENTS RECEIVED WITH A DELINQUENCY WILL BE APPLIED TO THE OLDEST DELINQUENT TAX YEAR. TO AVOID LATE CHARGES, PAYMENTS MUST BE RECEIVED OR POSTMARKED BY THE DUE DATE.

Values	Amount	Exemptions and Credits	Amount	Exemptions and Credits	Amount
Land Value	61,511				
Improvement Value	298,330				
Total Taxable					359,841

Taxing District	Phone	Rate	Total	Spec. Assessments	Phone	Rate	Total
Valley County	208-382-7100	0.0014608800	\$525.70	Forest Practices Act		0	3.24
School #421	208-634-2161	0.0012707650	\$457.27	Forest Assessment		0	55.00
School #421 Bond	208-634-2161	0.0005322710	\$191.53	North Lake S/W Bill		0	427.49
School #421 Tort	208-634-2161	0.0000068590	\$2.47	Solid Waste		0	110.00
Valley Center Cemetery	208-315-4521	0.0000328430	\$11.82				
Donnelly Rural Fire District	208-325-8619	0.0007789260	\$280.29				
North Lake Rec Sewer/Water	208-325-8958	0.0002771860	\$99.74				
McCall Memorial Hospital	208-271-6678	0.0003064940	\$110.29				
Valley County EMS District	208-382-7100	0.0002237070	\$80.50				
Edwards Mosquito Abatement	208-315-2101	0.0002374670	\$85.45				
Donnelly Public Library	208-325-8237	0.0000487830	\$17.55				
				Urban Renewal	Phone	Rate	Total

Bill Summary	Prior Year	Current	Delinquent	Interest	Late Fee	Fees	Paid	Total Due
	1,768.40	\$2,458.34	\$0.00	\$0.00	\$0.00	\$0.00	\$0.00	\$2,458.34

The mortgage companies have received a copy of the Valley County Tax File. If your mortgage company pays your taxes this notice is for information only. Credit and debit card payments are accepted through our website www.co.valley.id.us. All card transactions require your tax bill PIN, and are subject to a 2.50% convenience fee.

Make Check Payable to: VALLEY COUNTY TAX COLLECTOR

Keep top portion for your records

**FOR PROPER CREDIT RETURN THIS STUB WITH PAYMENT
 PERSONAL CHECKS ARE SUBJECT TO BANK CLEARANCE**

**FOR PROPER CREDIT RETURN THIS STUB WITH PAYMENT
 PERSONAL CHECKS ARE SUBJECT TO BANK CLEARANCE**

TIPPETTS WENDY
 595 S 14TH ST
 BOISE ID 83702

TIPPETTS WENDY
 595 S 14TH ST
 BOISE ID 83702

Bill Number: 2020 - 115258
 PIN: RP00180003002A
 AIN:
 VALLEY COUNTY

1ST HALF	\$1,229.17
FULL AMOUNT	

Bill Number: 2020 - 115258
 PIN: RP00180003002A
 AIN:
 VALLEY COUNTY

2ND HALF	\$1,229.17
-----------------	-------------------

\$2,458.34

December 21, 2020

June 21, 2021



VALLEY COUNTY CANCELLATION OF TAXES

Cancellation #: 21-10

Parcel #: RP001810020120

Tax Years: 2020

Bill #: 104586

Code Area: 039-0000

Name: JESSE PRAZENICA

Address: PO BOX 778

City / State / Zip: DONNELLY, ID 83615

Amount of Cancellation: Tax: \$0.00 Special Assessment: \$ 1497.65 P & I Charge: \$ 0.00

Fee: \$ 0.00 Paid: \$ Total: \$1497.65

Explanation: The fees were paid to Northlake and were not taken off the list to be certified.

Cancellation requested by: Gabe Stayton

Cancelled By Board of Commissioners:

Date: 12/7/20

Approved: Disapproved:

Chairman's Signature: Alting G. Husband

Date Treasurer Notified: 12/7/20

Date Treasurer Cancelled: 12/8/20

Date Auditor Notified: 12/7/20

Date Assessor Notified: 12/7/20

VALLEY COUNTY TAX STATEMENT

#10

GABE STAYTON
VALLEY COUNTY TAX COLLECTOR

P.O. Box 1350
 Cascade, ID 83611
 208-382-7110

Tax Year: 2020
 AIN: RP001810020120
 PIN:
 Code-Area: 039-0000

Bill Number: 104586
 Billing Date: 12/01/2020
 Balance good until: 12/01/2020
 Last Payment:

AUTO

 PRAZENICA JESSE J
 PO BOX 778
 DONNELLY ID 83615

Parcel Description: MCLEOD & EDWARDS WAGON WHEEL SUBDIVISION NO.
 8 LOT 12 BLOCK 2

Location: 12756 SKAIN RD
 Acres: 0.7714
 Mortgage: Lereta

PAYMENTS RECEIVED WITH A DELINQUENCY WILL BE APPLIED TO THE
 OLDEST DELINQUENT TAX YEAR. TO AVOID LATE CHARGES, PAYMENTS
 MUST BE RECEIVED OR POSTMARKED BY THE DUE DATE.

Values	Amount	Exemptions and Credits	Amount	Exemptions and Credits	Amount
Land Value	58,494	Homeowners Exemption	100,000		
Improvement Value	331,262				
				Total Taxable	289,756

Taxing District	Phone	Rate	Total	Spec. Assessments	Phone	Rate	Total
Valley County	208-382-7100	0.0014608800	\$423.31	Forest Practices Act		0	3.24
School #421	208-634-2161	0.0012707650	\$368.21	Forest Assessment		0	55.00
School #421 Bond	208-634-2161	0.0005322710	\$154.23	North Lake S/W Bill		0	1,497.65
School #421 Tort	208-634-2161	0.0000068590	\$1.99	Solid Waste		0	110.00
Valley Center Cemetery	208-315-4521	0.0000328430	\$9.52				
Donnelly Rural Fire District	208-325-8619	0.0007789260	\$225.70				
North Lake Rec Sewer/Water	208-325-8958	0.0002771880	\$80.32				
McCall Memorial Hospital	208-271-6678	0.0003064940	\$88.81				
Valley County EMS District	208-382-7100	0.0002237070	\$64.82				
Edwards Mosquito Abatement	208-315-2101	0.0002374670	\$68.81				
Donnelly Public Library	208-325-8237	0.0000487630	\$14.13				

Bill Summary	Prior Year	Current	Delinquent	Interest	Late Fee	Fees	Paid	Total Due
	3,003.22	\$3,165.74	\$3,003.22	\$338.40	\$60.06	\$0.00	\$0.00	\$6,567.42

The mortgage companies have received a copy of the Valley County Tax File. If your mortgage company pays your taxes this notice is for information only. Credit and debit card payments are accepted through our website www.co.valley.id.us. All card transactions require your tax bill PIN, and are subject to a 2.50% convenience fee.

Make Check Payable to: VALLEY COUNTY TAX COLLECTOR

Keep top portion for your records

**FOR PROPER CREDIT RETURN THIS STUB WITH PAYMENT
 PERSONAL CHECKS ARE SUBJECT TO BANK CLEARANCE**

**FOR PROPER CREDIT RETURN THIS STUB WITH PAYMENT
 PERSONAL CHECKS ARE SUBJECT TO BANK CLEARANCE**

PRAZENICA JESSE J
 PO BOX 778
 DONNELLY ID 83615

PRAZENICA JESSE J
 PO BOX 778
 DONNELLY ID 83615

Bill Number: 2020 - 104586
 PIN: RP001810020120
 AIN:
 VALLEY COUNTY

1ST HALF
 \$4,984.55
FULL AMOUNT

Bill Number: 2020 - 104586
 PIN: RP001810020120
 AIN:
 VALLEY COUNTY

2ND HALF
 \$1,582.87

\$6,567.42

December 21, 2020

June 21, 2021

Sent to Mortgage Company

Sent to Mortgage Company



VALLEY COUNTY CANCELLATION OF TAXES

Cancellation #: 21-11

Parcel #: RP00188000015A

Tax Years: 2020

Bill #: 700505

Code Area: 039-0000

Name: MANSON CAVERLY

Address: 19400 133RD AVE N

City / State / Zip: ROGERS, MN 55374

Amount of Cancellation: Tax: \$0.00 Special Assessment: \$ 101.50 P & I Charge: \$ 0.00

Fee: \$ 0.00 Paid: \$ Total: \$101.50

Explanation: The fees were paid to Northlake and were not taken off the list to be certified.

Cancellation requested by: Gabe Stayton

Cancelled By Board of Commissioners:

Date: 12/7/20

Approved: Disapproved:

Chairman's Signature: Elthij G. Hasbrouck

Date Treasurer Notified: 12/7/20

Date Treasurer Cancelled: 12/8/20

Date Auditor Notified: 12/7/20

Date Assessor Notified: 12/7/20

VALLEY COUNTY CANCELLATION OF TAXES

Cancellation #: 21-12

Parcel #: RP002260020050

Tax Years: 2020

Bill #: 105185

Code Area: 039-0000

Name: CAL COPE

Address: PO BOX 1506

City / State / Zip: EAGLE, ID 83616

Amount of Cancellation: Tax: \$0.00 Special Assessment: \$ 406.00 P & I Charge: \$ 0.00

Fee: \$ 0.00 Paid: \$ Total: \$406.00

Explanation: The fees were paid to Northlake and were not taken off the list to be certified.

Cancellation requested by: Gabe Stayton

Cancelled By Board of Commissioners:

Date: 12/7/20

Approved: Disapproved:

Chairman's Signature: Elting A. Hasbrouck

Date Treasurer Notified: 12/7/20

Date Treasurer Cancelled: 12/8/20

Date Auditor Notified: 12/7/20

Date Assessor Notified: 12/7/20

#12

VALLEY COUNTY TAX STATEMENT

GABE STAYTON
VALLEY COUNTY TAX COLLECTOR
 P.O. Box 1350
 Cascade, ID 83611
 208-382-7110

Tax Year: 2020 Bill Number: 105185
 AIN: Billing Date: 12/01/2020
 PIN: RP002280020050 Balance good until: 12/01/2020
 Code-Area: 039-0000 Last Payment:

Parcel Description: ROYAL SCOT SUBDIVISION NO. 2 LOT 5 BLOCK 2

Location: 2151 WEST MOUNTAIN RD
 Acres: 0.4664
 Mortgage:

PAYMENTS RECEIVED WITH A DELINQUENCY WILL BE APPLIED TO THE OLDEST DELINQUENT TAX YEAR. TO AVOID LATE CHARGES, PAYMENTS MUST BE RECEIVED OR POSTMARKED BY THE DUE DATE

AUTO

 COPE CAL KEITH
 PO BOX 1506
 EAGLE ID 83616

Values	Amount	Exemptions and Credits	Amount	Exemptions and Credits	Amount
Land Value	50,299				
Improvement Value	0				
Total Taxable					50,299

Taxing District	Phone	Rate	Total	Spec. Assessments	Phone	Rate	Total
Valley County	208-382-7100	0.0014608800	\$73.49	Forest Practices Act		0	1.60
School #421	208-634-2161	0.0012707650	\$63.92	Forest Assessment		0	7.40
School #421 Bond	208-634-2161	0.0005322710	\$26.77	North Lake S/W Bill		0	406.00
School #421 Tort	208-634-2161	0.0000068590	\$0.35				
Valley Center Cemetery	208-315-4521	0.0000328430	\$1.65				
Donnelly Rural Fire District	208-325-8619	0.0007789260	\$39.18				
North Lake Rec Sewer/Water	208-325-8958	0.0002771860	\$13.94				
McCall Memorial Hospital	208-271-8678	0.0003064940	\$15.42				
Valley County EMS District	208-382-7100	0.0002237070	\$11.25				
Edwards Mosquito Abatement	208-315-2101	0.0002374870	\$11.94				
Donnelly Public Library	208-325-8237	0.0000487630	\$2.45				
				Urban Renewal	Phone	Rate	Total

Bill Summary	Prior Year	Current	Delinquent	Interest	Late Fee	Fees	Paid	Total Due
	715.68	\$675.36	\$889.76	\$121.56	\$17.80	\$0.00	\$0.00	\$1,704.48

The mortgage companies have received a copy of the Valley County Tax File. If your mortgage company pays your taxes this notice is for information only. Credit and debit card payments are accepted through our website www.co.valley.id.us. All card transactions require your tax bill PIN, and are subject to a 2.50% convenience fee.

Make Check Payable to: VALLEY COUNTY TAX COLLECTOR **Keep top portion for your records**

FOR PROPER CREDIT RETURN THIS STUB WITH PAYMENT
PERSONAL CHECKS ARE SUBJECT TO BANK CLEARANCE

COPE CAL KEITH
 PO BOX 1506
 EAGLE ID 83616

FOR PROPER CREDIT RETURN THIS STUB WITH PAYMENT
PERSONAL CHECKS ARE SUBJECT TO BANK CLEARANCE

COPE CAL KEITH
 PO BOX 1506
 EAGLE ID 83616

Bill Number: 2020 - 105185
 PIN: RP002280020050
 AIN:
 VALLEY COUNTY

1ST HALF

FULL AMOUNT

Bill Number: 2020 - 105185
 PIN: RP002280020050
 AIN:
 VALLEY COUNTY

2ND HALF

\$1,704.48
 December 21, 2020

\$337.68
 June 21, 2021



VALLEY COUNTY CANCELLATION OF TAXES

Cancellation #: 21-13

Parcel #: RP002260020060

Tax Years: 2020

Bill #: 105760

Code Area: 039-0000

Name: CAL COPE

Address: PO BOX 1506

City / State / Zip: EAGLE, ID 83616

Amount of Cancellation: Tax: \$0.00 Special Assessment: \$ 512.04 P & I Charge: \$ 0.00

Fee: \$ 0.00 Paid: \$ Total: \$512.04

Explanation: The fees were paid to Northlake and were not taken off the list to be certified.

Cancellation requested by: Gabe Stayton

Cancelled By Board of Commissioners:

Date: 12/7/20

Approved: Disapproved:

Chairman's Signature: Elting D. Hasbrouck

Date Treasurer Notified: 12/7/20

Date Treasurer Cancelled: 12/8/20

Date Auditor Notified: 12/7/20

Date Assessor Notified: 12/7/20

VALLEY COUNTY TAX STATEMENT

#123

GABE STAYTON
VALLEY COUNTY TAX COLLECTOR
 P.O. Box 1350
 Cascade, ID 83611
 208-382-7110

Tax Year: 2020
 AIN: RP002260020060
 PIN:
 Code-Area: 039-0000

Bill Number: 105760
 Billing Date: 12/01/2020
 Balance good until: 12/01/2020
 Last Payment:

Parcel Description: ROYAL SCOT SUBDIVISION NO. 2 LOT 6 BLOCK 2
Location: 2153 WEST MOUNTAIN RD Acres: 0.4808
Mortgage:
PAYMENTS RECEIVED WITH A DELINQUENCY WILL BE APPLIED TO THE OLDEST DELINQUENT TAX YEAR. TO AVOID LATE CHARGES, PAYMENTS MUST BE RECEIVED OR POSTMARKED BY THE DUE DATE.

AUTO

 COPE CAL KEITH
 PO BOX 1506
 EAGLE ID 83616

Values	Amount	Exemptions and Credits	Amount	Exemptions and Credits	Amount
Land Value	50,759				
Improvement Value	122,917				
Total Taxable					173,676

Taxing District	Phone	Rate	Total	Spec. Assessments	Phone	Rate	Total
Valley County	208-382-7100	0.0014608800	\$253.72	Forest Practices Act		0	1.64
School #421	208-634-2161	0.0012707650	\$220.70	Forest Assessment		0	47.60
School #421 Bond	208-634-2161	0.0005322710	\$92.44	North Lake SAW Bill		0	512.04
School #421 Tort	208-634-2161	0.0000068590	\$1.19	Solid Waste		0	110.00
Valley Center Cemetery	208-315-4521	0.0000328430	\$5.70				
Donnelly Rural Fire District	208-325-8619	0.0007789260	\$135.28				
North Lake Rec Sewer/Water	208-325-8958	0.0002771860	\$48.14				
McCall Memorial Hospital	208-271-6678	0.0003064940	\$53.23				
Valley County EMS District	208-382-7100	0.0002237070	\$38.85				
Edwards Mosquito Abatement	208-315-2101	0.0002374670	\$41.24				
Donnelly Public Library	208-325-8237	0.0000487630	\$8.47				
				Urban Renewal	Phone	Rate	Total

Bill Summary	Prior Year	Current	Delinquent	Interest	Late Fee	Fees	Paid	Total Due
	1,571.60	\$1,570.24	\$3,095.77	\$603.06	\$61.89	\$0.00	\$1.94	\$5,329.02

The mortgage companies have received a copy of the Valley County Tax File. If your mortgage company pays your taxes this notice is for information only. Credit and debit card payments are accepted through our website www.co.valley.id.us. All card transactions require your tax bill PIN, and are subject to a 2.50% convenience fee.

Make Check Payable to: VALLEY COUNTY TAX COLLECTOR

Keep top portion for your records

FOR PROPER CREDIT RETURN THIS STUB WITH PAYMENT
PERSONAL CHECKS ARE SUBJECT TO BANK CLEARANCE

FOR PROPER CREDIT RETURN THIS STUB WITH PAYMENT
PERSONAL CHECKS ARE SUBJECT TO BANK CLEARANCE

COPE CAL KEITH
 PO BOX 1506
 EAGLE ID 83616

COPE CAL KEITH
 PO BOX 1506
 EAGLE ID 83616

Bill Number: 2020 - 105760
 PIN: RP002260020060
 AIN:
 VALLEY COUNTY

1ST HALF
\$4,543.90
FULL AMOUNT

Bill Number: 2020 - 105760
 PIN: RP002260020060
 AIN:
 VALLEY COUNTY

2ND HALF
\$785.12

\$5,329.02

December 21, 2020

June 21, 2021



VALLEY COUNTY CANCELLATION OF TAXES

Cancellation #: 21-14

Parcel #: RP002860020020

Tax Years: 2020

Bill #: 106545

Code Area: 039-0000

Name: MATHEW ROMERO

Address: 611 3RD ST

City / State / Zip: MCCALL, ID 83638

Amount of Cancellation: Tax: \$0.00 Special Assessment: \$ 271.83 P & I Charge: \$ 0.00

Fee: \$ 0.00 Paid: \$ Total: \$271.83

Explanation: The fees were paid to Northlake and were not taken off the list to be certified.

Cancellation requested by: Gabe Stayton

Cancelled By Board of Commissioners:

Date: 12/7/20

Approved: Disapproved:

Chairman's Signature: *Elting D. Heston*

Date Treasurer Notified: 12/7/20

Date Treasurer Cancelled: 12/8/20

Date Auditor Notified: 12/7/20

Date Assessor Notified: 12/7/20

VALLEY COUNTY TAX STATEMENT

#14

GABE STAYTON
VALLEY COUNTY TAX COLLECTOR
 P.O. Box 1350
 Cascade, ID 83611
 208-382-7110

Tax Year: 2020
 AIN: RP002860020020
 PIN: 039-0000
 Code-Area: 039-0000

Bill Number: 106545
 Billing Date: 12/01/2020
 Balance good until: 12/01/2020
 Last Payment: 11/24/2020

Parcel Description: WAGON WHEEL RANCH #1 SUB LOT 2 - BLOCK 2
Location: 179 DURHAM LN Acres: 0.6510
Mortgage:
PAYMENTS RECEIVED WITH A DELINQUENCY WILL BE APPLIED TO THE OLDEST DELINQUENT TAX YEAR. TO AVOID LATE CHARGES, PAYMENTS MUST BE RECEIVED OR POSTMARKED BY THE DUE DATE.

AUTO

 ROMERO MATHEW L
 611 3RD ST
 MCCALL ID 83638

Values	Amount	Exemptions and Credits	Amount	Exemptions and Credits	Amount
Land Value	64,598				
Improvement Value	0				
Total Taxable					64,598

Taxing District	Phone	Rate	Total	Spec. Assessments	Phone	Rate	Total		
Valley County	208-382-7100	0.0014608800	\$94.37	Forest Practices Act		0	3.24		
School #421	208-634-2161	0.0012707650	\$82.09	Forest Assessment		0	15.00		
School #421 Bond	208-634-2161	0.0005322710	\$34.38	North Lake S/W Bill		0	271.83		
School #421 Tort	208-634-2161	0.0000068590	\$0.44						
Valley Center Cemetery	208-315-4521	0.0000328430	\$2.12						
Donnelly Rural Fire District	208-325-8619	0.0007789260	\$50.32						
North Lake Rec Sewer/Water	208-325-8958	0.0002771860	\$17.91						
McCall Memorial Hospital	208-271-6678	0.0003064940	\$19.80						
Valley County EMS District	208-382-7100	0.0002237070	\$14.45						
Edwards Mosquito Abatement	208-315-2101	0.0002374670	\$15.34						
Donnelly Public Library	208-325-8237	0.0000487630	\$3.15						
				Urban Renewal	Phone	Rate	Total		
Bill Summary		Prior Year	Current	Delinquent	Interest	Late Fee	Fees	Paid	Total Due
		479.24	\$624.44	\$0.00	\$0.00	\$0.00	\$0.00	\$624.44	\$0.00

The mortgage companies have received a copy of the Valley County Tax File. If your mortgage company pays your taxes this notice is for information only. Credit and debit card payments are accepted through our website www.co.valley.id.us. All card transactions require your tax bill PIN, and are subject to a 2.50% convenience fee.

Make Check Payable to: VALLEY COUNTY TAX COLLECTOR **Keep top portion for your records**

FOR PROPER CREDIT RETURN THIS STUB WITH PAYMENT
PERSONAL CHECKS ARE SUBJECT TO BANK CLEARANCE

ROMERO MATHEW L
 611 3RD ST
 MCCALL ID 83638

ROMERO MATHEW L
 611 3RD ST
 MCCALL ID 83638

Bill Number: 2020 - 106545
 PIN: RP002860020020
 AIN:
 VALLEY COUNTY

1ST HALF
 \$0.00
 FULL AMOUNT
 \$0.00

Bill Number: 2020 - 106545
 PIN: RP002860020020
 AIN:
 VALLEY COUNTY

2ND HALF
 \$0.00

December 21, 2020

June 21, 2021



VALLEY COUNTY CANCELLATION OF TAXES

Cancellation #: 21-15

Parcel #: RP00286002022A

Tax Years: 2020

Bill #: 700439

Code Area: 039-0000

Name: STEVEN MASON

Address: 12858 HEREFORD RD

City / State / Zip: DONNELLY, ID 83615

Amount of Cancellation: Tax: \$0.00 Special Assessment: \$ 427.49 P & I Charge: \$ 0.00

Fee: \$ 0.00 Paid: \$ Total: \$427.49

Explanation: The fees were paid to Northlake and were not taken off the list to be certified.

Cancellation requested by: Gabe Stayton

Cancelled By Board of Commissioners:

Date: 12/7/20

Approved: Disapproved:

Chairman's Signature: Elting D. Stashowich

Date Treasurer Notified: 12/7/20

Date Treasurer Cancelled: 12/8/20

Date Auditor Notified: 12/7/20

Date Assessor Notified: 12/7/20

VALLEY COUNTY TAX STATEMENT

#15

GABE STAYTON
VALLEY COUNTY TAX COLLECTOR
 P.O. Box 1350
 Cascade, ID 83611
 208-382-7110

Tax Year: 2020
 AIN: RP00286002022A
 PIN: RP00286002022A
 Code-Area: 039-0000

Bill Number: 700439
 Billing Date: 12/01/2020
 Balance good until: 12/01/2020
 Last Payment:

Parcel Description: WAGON WHEEL RANCH #1 SUB LOT 22 BLOCK 2 1976 GREAT LAKES 14X52 M.H. SER#550F07GL52X142FRS0046 ON MH ROLL
Location: 12858 HEREFORD RD Acres: 0.4631 Mortgage:
PAYMENTS RECEIVED WITH A DELINQUENCY WILL BE APPLIED TO THE OLDEST DELINQUENT TAX YEAR. TO AVOID LATE CHARGES, PAYMENTS MUST BE RECEIVED OR POSTMARKED BY THE DUE DATE.

AUTO

 MASON STEVEN H
 12858 HEREFORD RD
 DONNELLY ID 83615

Values	Amount	Exemptions and Credits	Amount	Exemptions and Credits	Amount
Land Value	55,231	Homeowners Exemption	45,199		
Improvement Value	35,166				
				Total Taxable	45,198

Taxing District	Phone	Rate	Total	Spec. Assessments	Phone	Rate	Total
Valley County	208-382-7100	0.0014608800	\$66.03	Forest Practices Act		0	3.24
School #421	208-634-2161	0.0012707850	\$57.44	Forest Assessment		0	55.00
School #421 Bond	208-634-2161	0.0005322710	\$24.06	North Lake S/W Bill		0	427.49
School #421 Tort	208-634-2161	0.0000088590	\$0.31	Solid Waste		0	110.00
Valley Center Cemetery	208-315-4521	0.0000328430	\$1.48				
Donnelly Rural Fire District	208-325-8619	0.0007789260	\$35.21				
North Lake Rec Sewer/Water	208-325-8958	0.0002771860	\$12.53				
McCall Memorial Hospital	208-271-6678	0.0003064940	\$13.85				
Valley County EMS District	208-382-7100	0.0002237070	\$10.11				
Edwards Mosquito Abatement	208-315-2101	0.0002374670	\$10.73				
Donnelly Public Library	208-325-8237	0.0000467630	\$2.20				
				Urban Renewal	Phone	Rate	Total

Bill Summary	Prior Year	Current	Delinquent	Interest	Late Fee	Fees	Paid	Total Due
	871.80	\$829.68	\$2,328.89	\$506.95	\$46.59	\$0.00	\$64.72	\$3,647.39

The mortgage companies have received a copy of the Valley County Tax File. If your mortgage company pays your taxes this notice is for information only. Credit and debit card payments are accepted through our website www.co.valley.id.us. All card transactions require your tax bill PIN, and are subject to a 2.50% convenience fee.

Make Check Payable to: VALLEY COUNTY TAX COLLECTOR

Keep top portion for your records

**FOR PROPER CREDIT RETURN THIS STUB WITH PAYMENT
 PERSONAL CHECKS ARE SUBJECT TO BANK CLEARANCE**

**FOR PROPER CREDIT RETURN THIS STUB WITH PAYMENT
 PERSONAL CHECKS ARE SUBJECT TO BANK CLEARANCE**

MASON STEVEN H
 12858 HEREFORD RD
 DONNELLY ID 83615

MASON STEVEN H
 12858 HEREFORD RD
 DONNELLY ID 83615

Bill Number: 2020 - 700439
 PIN: RP00286002022A
 AIN:
 VALLEY COUNTY

1ST HALF
\$3,232.55
FULL AMOUNT

Bill Number: 2020 - 700439
 PIN: RP00286002022A
 AIN:
 VALLEY COUNTY

2ND HALF
\$414.84

\$3,647.39

December 21, 2020

June 21, 2021



VALLEY COUNTY CANCELLATION OF TAXES

Cancellation #: 21-16

Parcel #: RP002920000430

Tax Years: 2020

Bill #: 105969

Code Area: 039-0000

Name: RACHEL SHROPE

Address: PO BOX 1105

City / State / Zip: MCCALL, ID 83638

Amount of Cancellation: Tax: \$0.00 Special Assessment: \$ 101.56 P & I Charge: \$ 0.00

Fee: \$ 0.00 Paid: \$ Total: \$101.56

Explanation: The fees were paid to Northlake and were not taken off the list to be certified.

Cancellation requested by: Gabe Stayton

Cancelled By Board of Commissioners:

Date: 12/7/20

Approved: Disapproved:

Chairman's Signature: Elting D. Hasbrouck

Date Treasurer Notified: 12/7/20

Date Treasurer Cancelled: 12/8/20

Date Auditor Notified: 12/7/20

Date Assessor Notified: 12/7/20

VALLEY COUNTY TAX STATEMENT

11/10

GABE STAYTON
VALLEY COUNTY TAX COLLECTOR

P.O. Box 1350
 Cascade, ID 83611
 208-382-7110

Tax Year: 2020
 AIN: RP002920000430
 PIN:
 Code-Area: 039-0000

Bill Number: 105969
 Billing Date: 12/01/2020
 Balance good until: 12/01/2020
 Last Payment:

Parcel Description: WAGON WHEEL RANCH #3 SUB LOT 43 YEAR 2003 OAKWOOD 27X44 M.H. SER #G00R23N26466A
Location: 12834 CASCADE DR Acres: 0.6140 Mortgage: Lereta
PAYMENTS RECEIVED WITH A DELINQUENCY WILL BE APPLIED TO THE OLDEST DELINQUENT TAX YEAR. TO AVOID LATE CHARGES, PAYMENTS MUST BE RECEIVED OR POSTMARKED BY THE DUE DATE.

AUTO

 SHROPE RACHEL R
 PO BOX 1105
 MCCALL ID 83638

Values	Amount	Exemptions and Credits	Amount	Exemptions and Credits	Amount
Land Value	62,883	Homeowners Exemption	73,681		
Improvement Value	96,409				
				Total Taxable	85,611

Taxing District	Phone	Rate	Total	Spec. Assessments	Phone	Rate	Total
Valley County	208-382-7100	0.0014608800	\$125.06	Forest Practices Act		0	3.24
School #421	208-634-2161	0.0012707650	\$108.79	Forest Assessment		0	55.00
School #421 Bond	208-634-2161	0.0005322710	\$45.57	North Lake S/W Bill		0	101.56
School #421 Tort	208-634-2161	0.0000068590	\$0.59	Solid Waste		0	110.00
Valley Center Cemetery	208-315-4521	0.0000328430	\$2.81				
Donnelly Rural Fire District	208-325-8619	0.0007789260	\$66.68				
North Lake Rec Sewer/Water	208-325-8958	0.0002771860	\$23.73				
McCall Memorial Hospital	208-271-6678	0.0003064940	\$26.24				
Valley County EMS District	208-382-7100	0.0002237070	\$19.15				
Edwards Mosquito Abatement	208-315-2101	0.0002374670	\$20.33				
Donnelly Public Library	208-325-8237	0.0000487630	\$4.17				
				Urban Renewal	Phone	Rate	Total

Bill Summary	Prior Year	Current	Delinquent	Interest	Late Fee	Fees	Paid	Total Due
	642.38	\$712.92	\$0.00	\$0.00	\$0.00	\$0.00	\$0.00	\$712.92

The mortgage companies have received a copy of the Valley County Tax File. If your mortgage company pays your taxes this notice is for information only. Credit and debit card payments are accepted through our website www.co.valley.id.us. All card transactions require your tax bill PIN, and are subject to a 2.50% convenience fee.

Make Check Payable to: VALLEY COUNTY TAX COLLECTOR

Keep top portion for your records

**FOR PROPER CREDIT RETURN THIS STUB WITH PAYMENT
 PERSONAL CHECKS ARE SUBJECT TO BANK CLEARANCE**

**FOR PROPER CREDIT RETURN THIS STUB WITH PAYMENT
 PERSONAL CHECKS ARE SUBJECT TO BANK CLEARANCE**

SHROPE RACHEL R
 PO BOX 1105
 MCCALL ID 83638

SHROPE RACHEL R
 PO BOX 1105
 MCCALL ID 83638

Bill Number: 2020 - 105969
 PIN: RP002920000430
 AIN:
 VALLEY COUNTY

1ST HALF
\$356.46
 FULL AMOUNT

Bill Number: 2020 - 105969
 PIN: RP002920000430
 AIN:
 VALLEY COUNTY

2ND HALF
\$356.46

\$712.92

December 21, 2020

June 21, 2021

Sent to Mortgage Company

Sent to Mortgage Company



VALLEY COUNTY CANCELLATION OF TAXES

Cancellation #: 21-17

Parcel #: RP002920120420

Tax Years: 2020

Bill #: 115318

Code Area: 039-0000

Name: MBF PROPERTY TRUST

Address: 3 CORONET AVE

City / State / Zip: MILL VALLEY, CA 94941

Amount of Cancellation: Tax: \$0.00 Special Assessment: \$ 4602.69 P & I Charge: \$ 0.00

Fee: \$ 0.00 Paid: \$ Total: \$ 4602.69

Explanation: The fees were paid to Northlake and were not taken off the list to be certified.

Cancellation requested by: Gabe Stayton

Cancelled By Board of Commissioners:

Date: 12/7/20

Approved: Disapproved:

Chairman's Signature: Elting A. Hasbrouck

Date Treasurer Notified: 12/7/20

Date Treasurer Cancelled: 12/8/20

Date Auditor Notified: 12/7/20

Date Assessor Notified: 12/7/20

VALLEY COUNTY TAX STATEMENT

GABE STAYTON
VALLEY COUNTY TAX COLLECTOR

P.O. Box 1350
 Cascade, ID 83611
 208-382-7110

Tax Year: 2020
 AIN: RP004920120420
 PIN:
 Code-Area: 063-0000

Bill Number: 115318
 Billing Date: 12/01/2020
 Balance good until: 12/01/2020
 Last Payment:

117

Parcel Description: TAMARACK RESORT P.U.D. PHASE 1 LOT 42 BLOCK 12
Location: 94 SUGARLOAF PLACE Acres: 0.1470
Mortgage:
PAYMENTS RECEIVED WITH A DELINQUENCY WILL BE APPLIED TO THE OLDEST DELINQUENT TAX YEAR. TO AVOID LATE CHARGES, PAYMENTS MUST BE RECEIVED OR POSTMARKED BY THE DUE DATE.

Values	Amount	Exemptions and Credits	Amount	Exemptions and Credits	Amount
Land Value	250,000				
Improvement Value	568,599				
Total Taxable					818,599

Taxing District	Phone	Rate	Total	Spec. Assessments	Phone	Rate	Total		
Valley County	208-382-7100	0.0014608800	\$1,195.89	Forest Practices Act		0	3.24		
School #421	208-834-2161	0.0012707650	\$1,040.25	Forest Assessment		0	55.00		
School #421 Bond	208-634-2161	0.0005322710	\$435.72	North Lake SAW Bill		0	4,602.69		
School #421 Tort	208-634-2161	0.0000068590	\$5.81	Solid Waste		0	110.00		
Valley Center Cemetery	208-315-4521	0.0000328430	\$26.89						
Donnelly Rural Fire District	208-325-8619	0.0007789260	\$637.63						
North Lake Rec Sewer/Water	208-325-8958	0.0002771860	\$226.90						
Cascade Medical Center	208-382-4285	0.0007974390	\$652.78						
Valley County EMS District	208-382-7100	0.0002237070	\$183.13						
Edwards Mosquito Abatement	208-315-2101	0.0002374670	\$194.39						
Donnelly Public Library	208-325-8237	0.0000487630	\$39.92						
				Urban Renewal	Phone	Rate	Total		
Bill Summary		Prior Year	Current	Delinquent	Interest	Late Fee	Fees	Paid	Total Due
		9,320.10	\$9,410.04	\$20,141.06	\$4,359.02	\$402.82	\$0.00	\$0.00	\$34,312.94

The mortgage companies have received a copy of the Valley County Tax File. If your mortgage company pays your taxes this notice is for information only. Credit and debit card payments are accepted through our website www.co.valley.id.us. All card transactions require your tax bill PIN, and are subject to a 2.50% convenience fee.

Make Check Payable to: VALLEY COUNTY TAX COLLECTOR

Keep top portion for your records

**FOR PROPER CREDIT RETURN THIS STUB WITH PAYMENT
 PERSONAL CHECKS ARE SUBJECT TO BANK CLEARANCE**

**FOR PROPER CREDIT RETURN THIS STUB WITH PAYMENT
 PERSONAL CHECKS ARE SUBJECT TO BANK CLEARANCE**

MBF PROPERTY TRUST
 3 CORONET AVE
 MILL VALLEY CA 94941

MBF PROPERTY TRUST
 3 CORONET AVE
 MILL VALLEY CA 94941

Bill Number: 2020 - 115318
 PIN: RP004920120420
 AIN:
 VALLEY COUNTY

1ST HALF
\$29,607.92
FULL AMOUNT

Bill Number: 2020 - 115318
 PIN: RP004920120420
 AIN:
 VALLEY COUNTY

2ND HALF
\$4,705.02

\$34,312.94

December 21, 2020

June 21, 2021



VALLEY COUNTY CANCELLATION OF TAXES

Cancellation #: 21-18

Parcel #: RP005150050010

Tax Years: 2020

Bill #: 116702

Code Area: 039-0000

Name: RADIATAS OUTDOORS LLC

Address: 8671 WILSHIRE BLVD STE 700

City / State / Zip: BEVERLY HILLS, CA 90211

Amount of Cancellation: Tax: \$0.00 Special Assessment: \$ 1562.22 P & I Charge: \$ 0.00

Fee: \$ 0.00 Paid: \$ Total: \$ 1562.22

Explanation: The fees were paid to Northlake and were not taken off the list to be certified.

Cancellation requested by: Gabe Stayton

Cancelled By Board of Commissioners:

Date: 12/7/20

Approved: Disapproved:

Chairman's Signature: *Peter D. Haakrosch*

Date Treasurer Notified: 12/7/20

Date Treasurer Cancelled: 12/8/20

Date Auditor Notified: 12/7/20

Date Assessor Notified: 12/7/20

VALLEY COUNTY TAX STATEMENT

#10

GABE STAYTON
VALLEY COUNTY TAX COLLECTOR

P.O. Box 1350
 Cascade, ID 83611
 208-382-7110

Tax Year: 2020
 AIN: RP005150050010
 PIN:
 Code-Area: 039-0000

Bill Number: 116702
 Billing Date: 12/01/2020
 Balance good until: 12/01/2020
 Last Payment:

Parcel Description: TAMARACK RESORT P.U.D. PHASE 2.1 LOT 1 BLOCK 5
Location: 146 WHITEWATER DR Acres: 0.4130
Mortgage:
PAYMENTS RECEIVED WITH A DELINQUENCY WILL BE APPLIED TO THE OLDEST DELINQUENT TAX YEAR. TO AVOID LATE CHARGES, PAYMENTS MUST BE RECEIVED OR POSTMARKED BY THE DUE DATE.

AUTO

 C/O DE LOS PRADOS CPA
 RADIATAS OUTDOORS LLC
 8671 WILSHIRE BLVD STE 700
 BEVERLY HILLS CA 90211

Values	Amount	Exemptions and Credits	Amount	Exemptions and Credits	Amount
Land Value	150,000				
Improvement Value	0				
Total Taxable					150,000

Taxing District	Phone	Rate	Total	Spec. Assessments	Phone	Rate	Total
Valley County	208-382-7100	0.0014608800	\$219.15	Forest Practices Act		0	3.24
School #421	208-634-2161	0.0012707650	\$190.61	Forest Assessment		0	15.00
School #421 Bond	208-634-2161	0.0005322710	\$79.84	North Lake S/W Bill		0	1,562.22
School #421 Tort	208-634-2161	0.0000068590	\$1.03				
Valley Center Cemetery	208-315-4521	0.0000328430	\$4.93				
Donnelly Rural Fire District	208-325-8619	0.0007789260	\$116.84				
North Lake Rec Sewer/Water	208-325-8958	0.0002771860	\$41.58				
McCall Memorial Hospital	208-271-6678	0.0003064940	\$45.97				
Valley County EMS District	208-382-7100	0.0002237070	\$33.56				
Edwards Mosquito Abatement	208-315-2101	0.0002374870	\$35.62				
Donnelly Public Library	208-325-8237	0.0000487630	\$7.31				
				Urban Renewal	Phone	Rate	Total

Bill Summary	Prior Year	Current	Delinquent	Interest	Late Fee	Fees	Paid	Total Due
	2,145.96	\$2,356.90	\$2,932.43	\$391.86	\$58.64	\$0.00	\$272.40	\$5,467.43

The mortgage companies have received a copy of the Valley County Tax File. If your mortgage company pays your taxes this notice is for information only. Credit and debit card payments are accepted through our website www.co.valley.id.us. All card transactions require your tax bill PIN, and are subject to a 2.50% convenience fee.

Make Check Payable to: VALLEY COUNTY TAX COLLECTOR **Keep top portion for your records**

FOR PROPER CREDIT RETURN THIS STUB WITH PAYMENT
PERSONAL CHECKS ARE SUBJECT TO BANK CLEARANCE

C/O DE LOS PRADOS CPA
 RADIATAS OUTDOORS LLC
 8671 WILSHIRE BLVD STE 700
 BEVERLY HILLS CA 90211

Bill Number: 2020 - 116702
 PIN: RP005150050010
 AIN:
 VALLEY COUNTY

1ST HALF

\$4,288.98

FULL AMOUNT

\$5,467.43

FOR PROPER CREDIT RETURN THIS STUB WITH PAYMENT
PERSONAL CHECKS ARE SUBJECT TO BANK CLEARANCE

C/O DE LOS PRADOS CPA
 RADIATAS OUTDOORS LLC
 8671 WILSHIRE BLVD STE 700
 BEVERLY HILLS CA 90211

Bill Number: 2020 - 116702
 PIN: RP005150050010
 AIN:
 VALLEY COUNTY

2ND HALF

\$1,178.45

December 21, 2020

June 21, 2021



VALLEY COUNTY CANCELLATION OF TAXES

Cancellation #: 21-19

Parcel #: RP0055440080430

Tax Years: 2020

Bill #: 118277

Code Area: 039-0000

Name: NANCY JETSEL

Address: 6786 N EXETER AVE

City / State / Zip: MERIDIAN, ID 83646

Amount of Cancellation: Tax: \$0.00 Special Assessment: \$ 194.72 P & I Charge: \$ 0.00

Fee: \$ 0.00 Paid: \$ Total: \$ 194.72

Explanation: The fees were paid to Northlake and were not taken off the list to be certified.

Cancellation requested by: Gabe Stayton

Cancelled By Board of Commissioners:

Date: 12/7/20

Approved: Disapproved:

Chairman's Signature: Elting A. Hasbrouk

Date Treasurer Notified: 12/7/20

Date Treasurer Cancelled: 12/8/20

Date Auditor Notified: 12/7/20

Date Assessor Notified: 12/7/20

Valley County Board of County Commissioners

PO Box 1350 • 219 N Main Street
Cascade, Idaho 83611-1350



Phone (208) 382-7100
Fax (208) 382-7107

ELTING G. HASBROUCK
Chairman of the Board
ehasbrouck@co.valley.id.us

DAVID H. BINGAMAN
Commissioner
dbingaman@co.valley.id.us

SHERRY MAUPIN
Commissioner
smaupin@co.valley.id.us

DOUGLAS A. MILLER
Clerk
dmiller@co.valley.id.us

VALLEY COUNTY COMMISSIONERS MEETING AGENDA Monday December 7, 2020

In an effort to minimize possible public exposure to COVID-19, the Valley County Board of County Commissioners will continue to hold regular Commissioner meetings, but they will be closed to public attendance. In an effort to promote full transparency the meetings will be live streamed and may be viewed by accessing the Valley County web site at www.co.valley.id.us There will be prompts at that site to guide you to the live stream. If a member of the public wishes to make a public comment about any of the matters pending, please contact the Valley County Clerk, Douglas Miller at 208-382-7102 to make those arrangements

PROPOSED AGENDA Note: Any item(s) in need of a motion will be described in the agenda under the appropriate section.

- 9:00 Call to Order – Pledge of Allegiance – Approve Agenda
- 9:05 Commissioner Discussion
Action Items: Meeting Minutes of November 23, 2020 and November 30, 2020
Valley County Local Housing Site/Soil Evaluation and Seasonal Groundwater Monitoring Agreement with Crestline Engineering
- 9:05 **Action Item:** Approval of Blue Line Maps-Road Superintendent, Jeff McFadden
- 9:15 **Action Items:** V-3-20 RMC Flagpole
Approval to Withdraw Appeal of P&Z Approval of Blackhawk on the River Final Plat-Planning and Zoning Administrator, Cynda Herrick
- 9:30 Central District Health Presentation-Executive Director, Russ Duke
- 10:30 **Action Item: Public Hearing CA-20-03**
General Development Standards Code Amendments
Michelle Groenevelt for the City of McCall: A Code Amendment application to codify the existing McCall Area Design Guidelines and to amend the existing Development Standards for McCall City Limits and Impact Area Code Title 3: Planning and Zoning and Title 9 Subdivision and Development.

- 11:30 Boise National Forest Presentation-District Ranger, Jake Strohmeier
Action Item: FY21 Annual Operating Plan with Boise National Forest
 Snowmobile Trail Grooming Program
- 12:00 **Action Item:** Executive Session per Idaho Code 74-206 1(b)-“to consider the evaluation, dismissal or disciplining of, or to hear complaints or charges brought against, a public officer, employee, staff member or individual agent, or public school student.”-Personnel
- 1:00 Service Award Presentation-Human Resource Director, Pat Duncan
- 1:05 **Action Item:** Cancellation of Property Taxes #21-1 through #21-19 – Treasure, Gabe Stayton
- 1:15 **Action Item:** Schedule a Joint Meeting with McCall City Council to Discuss Endowment Lands
- 1:30 **Action Item:** Public Hearing Ordinance 21-02 Snowmobile Ordinance
- 2:30 **Action Item:** Approval of Website Upgrade and Master Services Agreement EvoGov-IT Director, David Crawford
- 3:00 **Action Items:** Emergency Funds Application for Zena Creek Bridge
 Signing Credit Application for Rush Enterprises - Road and Bridge Superintendent, Jeff McFadden
- 3:15 **Action Item:** Cancellation of Value #18 RPM00000096979
 Cancellation of Value #19 RPM00000096981 – Assessor, June Fullmer
- 3:30 **Action Item:** Executive Session per Idaho Code 74-206 1(b)-“to consider the evaluation, dismissal or disciplining of, or to hear complaints or charges brought against, a public officer, employee, staff member or individual agent, or public school student.”-Personnel

Adjourn

COMMISSIONER’S FUTURE MEETING DATE

Monday December 14, 2020